



KAC50DP - BC100DE Energy Storage System

User Manual



Version: V1.0

Date of release: 2023-10-10

Contents

1 About This Manual.....	1
1.1 Applicable Products	1
1.2 Introduction	1
1.3 Applicable Personnel	1
1.4 Use of Symbols.....	2
1.5 Use of the Manual.....	3
2 Safety Instructions.....	3
2.1 General Safety Rules	4
2.2 Personnel Requirements.....	4
2.3 Manual Storage.....	5
2.4 Battery Protection.....	5
2.5 Ground Fault Protection	5
2.6 Live Line Measurement.....	5
2.7 Use of Measuring Equipment	5
2.8 Complete Power-off Operation	6
2.9 Arc Protection	6
2.10 Electrostatic Protection	7
2.11 LCD Parameter Setting.....	7
2.12 Sand and Moisture Protection.....	7
2.13 Body Warning Signs Protection	7
2.14 Safety Warning Sign Protection	8
2.15 Transport and Inspection.....	8
2.16 Installation and Commissioning.....	8
2.17 Daily Operation and Maintenance.....	9
2.18 Product Scrapping.....	9
3 Product Description.....	10
3.1 Product Overview	10
3.2 Appearance Design	12
3.2.1 Appearance Introduction.....	12

3.2.2 Mechanical Parameters	12
3.3 System Architecture.....	14
3.3.1 System Overview.....	14
3.3.1.1 Overview of the Location of Electrical Components.....	15
3.3.1.2 Battery Module.....	16
3.3.1.3 EMS-HMI.....	18
3.3.2 PCS.....	22
4 Delivery and Storage.....	24
4.1 Scope of Supply.....	24
4.2 Check Shipping Integrity	26
4.3 Storage	26
5 Mechanical Installation.....	28
5.1 Conditions of Transport	28
5.2 Forklift Transportation	28
5.3 Building Foundation	30
5.3.1 Selection of Installation Site.....	30
5.3.2 Foundation Requirements	30
5.4 Fixed Installation	32
6 Electrical Connection	34
6.1 Safety Precautions	34
6.1.1 General.....	34
6.1.2 Five Safety Rules	35
6.2 Wiring Parts.....	36
6.2.1 System Cables	37
6.2.2 AC side making terminal	39
6.2.3 PV terminal making.....	40
6.2.4 Auxiliary power input line terminals making	41
6.2.5 Battery connection wire terminals making.....	41
6.3 Electrical Wiring Preparation	42
6.3.1 Tools for Installation	42
6.3.2 Checking Cables	43
6.3.3 Precautions when Wiring.....	43

6.4 Earth Connection	43
6.4.1 Introduction	43
6.4.2 Equipotential Bonding of Internal Devices	44
6.4.3 External Earthing.....	44
6.5 System Wiring	45
6.5.1 Safety Precautions	45
6.5.2 Wiring Overview.....	46
6.6 Battery Auxiliary Wiring Steps	47
6.7 Communication Interface Wiring.....	48
6.8 Wiring and Waterproof Treatment.....	49
6.9 Closing Electrical Connections	49
7 Battery Description.....	50
7.1 Battery Connection	50
7.1.1 Introduction	50
7.1.2 Power Cord Connection	50
7.1.3 Communication Cable Connection	50
7.2 Commissioning.....	50
8 Power On/Off Operation	51
8.1 Check before Power-on	51
8.2 Power-on Operation	51
8.3 Power-off Operation	52
9 LCD Operation	53
9.1 LCD Screen Position	53
9.2 Backlight Function.....	53
9.3 Start Page.....	53
9.4 Device Information Page.....	55
9.4.1 Device-KAC Page	55
9.4.2 Device-Battery Page.....	60
9.4.3 Device-Ambient Page.....	62
9.4.4 Device-Meter Page.....	62

9.5 Alarm Page	63
9.5.1 Alarm-Alarm Information Page	63
9.5.2 Alarm-Alarm Log Page.....	64
9.5.3 Alarm-System Log Page.....	64
9.6 Settings Page.....	65
9.6.1 Settings-General Settings Page	65
9.6.2 Settings-Timesharing Power Settings Page.....	66
9.6.3 Settings-Control Settings Page	67
9.6.4 Settings-Language Settings Page	72
10 Troubleshooting.....	73
10.1 Node Failure Information & Troubleshooting Methods	73
10.2 Alarm Positioning and Troubleshooting	77
11.1 General.....	78
11.2 Firefighting System Introduction	78
12 Daily Operation and Maintenance	80
12.1 Safety Precautions	80
12.2 Maintenance Introduction	80
12.2.1 Overview	80
12.2.2 Maintenance Cycle.....	81
12.3 System Cleaning	84
12.3.1 Overview	84
12.3.2 Cleaning Cycle	84
12.3.3 Internal Cleaning.....	84
12.3.4 Internal Cleaning of the Foundation	84
12.3.5 Checking Door Locks and Hinges	84
12.3.6 Checking Sealing Strips	84
12.4 Paint Touch-up Measures	85
14 Appendix.....	86
14.1 System Wiring Diagram.....	86
14.2 Single System Parameters.....	87
14.3 Tightening Torques	88

14.4 First Run Parameter Settings	89
14.5 Quality Assurance	92
14.6 Contact Information.....	93

1 About This Manual

1.1 Applicable Products

This manual is applicable to the following models of integrated energy storage systems.

KAC50DP - BC100DE

Explanation of Integrated ESS Model:

- AC: Power Conversion System
- 50: Rated power of PCS
- DP: Outdoor unit with PV
- BC: Battery cabinet
- 100: 100KWH battery capacity (specific equipment capacity based on the actual product)
- DE: Outdoor cabinet with EMS

1.2 Introduction

This manual contains the following main contents:

Content	Description
Safety instructions	Introduces the safety matters that need to be paid attention to when installing, running, maintaining, and overhauling the integrated ESS
Product description	Introduces the appearance, performance, composition and internal equipment layout of the integrated ESS
Delivery	Delivery and inspection when the user receives the product, etc.
Installation	Introduces the mechanical transportation, installation, and electrical connection methods of the integrated ESS
Power on/off	The steps to turn on/off the internal equipment during normal maintenance/overhaul, etc.
LCD operation	Functions and usage methods of the man-machine interface, etc.
Firefighting instructions	Introduce the main firefighting equipment in the integrated ESS
Function	Description of main functions
Troubleshooting	Simple troubleshooting methods, etc.
Daily operation guidance	Introduces the daily operation precautions and daily maintenance guidance of the integrated ESS
Others	Introduce the technical data of the integrated ESS, the terms of quality assurance and the contact information with our company, etc.

1.3 Applicable Personnel

This manual is suitable for those who transport, install and operate the integrated ESS. Readers must at least meet the following requirements:

- Have certain electronic, electrical wiring and mechanical expertise, and be familiar with electrical and mechanical schematic diagrams.

- Be familiar with the composition and working principle of the integrated ESS; be familiar with the composition and working principle of the integrated ESS and its front and back level equipment.
- Have received professional training related to electrical equipment installation and commissioning.
- Have emergency response capabilities for dangerous or unexpected situations that arise during installation or trial operation.
- Be familiar with the relevant standards and codes of the country where the project is located.
- Be familiar with what is described in this manual.

Only personnel who meet the above requirements can perform installation, operation and maintenance, inspection and other operations on the integrated ESS. Unauthorized personnel should not perform any operations on the ESS, and should keep a sufficient safe distance from the system to avoid accidents.

1.4 Use of Symbols

In order to ensure the user’s personal and property safety when installing this product, or to use this product efficiently and optimally, relevant information is provided in the manual and highlighted with appropriate symbols.

The symbols that may be used in this manual are listed below. Please read carefully to use this manual better.



 **DANGER**
 “Danger” indicates a high potential hazard, which will result in serious accidents such as personal injury or death if not avoided.



 **WARNING**
 “Warning” indicates a moderate potential hazard, which may lead to serious accidents such as personal injury or death if not avoided.

 **CAUTION**
 “Caution” indicates a hazard with a low level of potential hazard which could result in moderate or minor injury if not avoided.

ATTENTION
 “Attention” indicates a potential risk, which could result in the equipment not running normally or cause property damage if not avoided.
 “Note” is additional information in the manual, emphasizing and supplementing the content, and may also provide tips or tricks for optimizing the use of the product, which can help you solve a certain problem or save your time.

Please always pay attention to the danger warning signs on the machine, including:

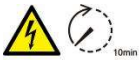
	This mark indicates that the internal body contains high voltage, which may cause electric shock hazard if touched.
	All external power connections must be disconnected before maintenance work on the equipment!

	<p>This symbol indicates that the temperature here is higher than the acceptable range of the human body. Do not touch it to avoid personal injury.</p>
	<p>Maintenance, inspection and other operations can only be carried out after the system is powered off for 10 minutes.</p>
	<p>During equipment operation, noise may be generated. It is recommended to wear mute earplugs.</p>
	<p>This symbol indicates that this is the protective earth (PE) terminal, which needs to be firmly grounded to ensure the safety of operators.</p>

1.5 Use of the Manual

Please read this manual carefully before transporting and installing this product. Keep this manual and materials about the product components properly to ensure that relevant personnel can access them at any time.

The content of the manual as well as the pictures, logos and symbols used are all owned by KSTAR. It is not allowed to publicly reproduce all or part of the content without written authorization of KSTAR.

Our products and product manuals are subject to improvement and upgrading in order to continuously improve customer satisfaction. If there is a discrepancy between the manual and the product, please refer to the specific product. If you still have questions, please contact KSTAR.

The System Manual of the internal electrical equipment of the integrated ESS is delivered with the equipment. Before installing and running the equipment, please read the manual carefully and follow the requirements in the manual.

- A large number of pictures are provided in the manual in order to facilitate your reading. The pictures are for illustrative purposes only. For the specific details of the product, please refer to the actual product received.
- Please keep this manual and other related documents close to the equipment for reference at any time during installation, operation, maintenance and overhaul.
- All descriptions in this manual refer to the standard configuration of the integrated ESS. If users have special needs, please describe to KSTAR staff when ordering. We will do our best to meet your needs. For specific details of the product, please refer to the actual product you receive.
- This manual can't cover all possible situations during installation, operation, maintenance, inspection, etc. If you encounter a situation that can't be explained in the manual, please contact KSTAR in time.

2 Safety Instructions

All safety instructions in this manual must be strictly followed at all times. In order to avoid possible casualties and property losses during installation or operation, and effectively prolong the service life of the integrated ESS, please read all safety instructions carefully.

2.1 General Safety Rules

DANGER

There is a risk of electric shock if you touch the power grid or the contacts and terminals connected to it inside the equipment!

- Do not touch terminals or conductors connected to the grid circuit.
- Observe all instructions or safety documentation regarding connection to the mains.

DANGER

Lethal high voltages exist inside the product!

- Note and abide by the warning signs on the product.
- Observe the safety precautions listed in this manual and other documents related to this equipment.
- Observe the relevant safety precautions and protection precautions for lithium batteries.

DANGER

Damaged equipment or system failure may cause electric shock or fire!

- Perform an initial visual inspection of the equipment for damage or other hazards prior to operation.
- Check whether other external devices or circuit connections are secure.
- Confirm that this equipment is in a safe state before operating it.

WARNING

The installation and various operations of the integrated ESS must comply with the relevant standards and regulations of the country/region where the project is located.



The outdoor cabinet of battery is equipped with an automatic fire extinguishing system, and the fire switch should not be triggered unless it is an emergency.

2.2 Personnel Requirements

- Only professional electricians or qualified personnel who understand the various safety precautions and the correct running methods can operate this product.
- Personnel who operate the equipment, including operators, trained personnel, and professionals should have special running qualifications required by the local state, such as high-voltage operation, ascent, and special equipment operation qualifications.
- Operators should be fully familiar with the composition and working principle of the integrated ESS.
- Operators should have training or experience in running the equipment and be aware of the various potential sources and levels of hazard during installation, operation, and maintenance of the equipment.

System Manual

- Operators should be fully familiar with the relevant standards and regulations of the country/region where the project is located.
- Operators should be fully familiar with the product manuals of outdoor cabinets and internal electrical equipment.

2.3 Manual Storage

The product manual is an integral and important part of the product. It includes important information about the transportation, installation, inspection and maintenance of the product. Please read this manual carefully before transporting, installing, overhauling, and maintaining the product.

- Please carry out operations such as transportation, installation, inspection and maintenance of the product in strict accordance with the descriptions in this manual, or equipment damage, casualties, and property losses may result.
- The manual should be kept in a safe place to ensure that the transportation, installation and operation personnel can obtain it at any time.

2.4 Battery Protection

DANGER

DC high voltage! Electric shock hazard!
The battery in the system generates a high voltage when it is connected. If accidentally touched, there will be electric shock or even life-threatening.

When installing, maintaining and overhauling the equipment, make sure that:

- The energy storage battery has been completely disconnected.
- Clear warning signs at the point of disconnection to ensure no accidental reconnection.

2.5 Ground Fault Protection

DANGER

When a ground fault occurs in the integrated ESS, there may be fatal high voltage in the parts that are not charged originally. Dangerous if accidentally touched! Before operation, please ensure that there is no ground fault in the system, and also take relevant protective measures.

2.6 Live Line Measurement

DANGER

There are high voltages in the equipment in the integrated ESS, and accidental touch may cause fatal electric shock hazards. Therefore, during live measurement, you should:

- Take appropriate protection (such as wearing insulating gloves, etc.).
- There must be an accompanying person to ensure personal safety.

2.7 Use of Measuring Equipment

When conducting electrical connection and trial operation of the integrated ESS, it is necessary to use relevant electrical measurement equipment in order to ensure that the electrical parameters meet the requirements.

 **DANGER**

- Select high-quality measuring equipment that meets the requirements of the site, such as measuring range and usable conditions.
- Make sure that the connection and use of the measuring equipment are correct and standardized, so as to avoid dangers such as electric arcs.
- For live measurement, take appropriate protection (such as wearing insulating gloves, etc.)

2.8 Complete Power-off Operation

Operations can be performed only when it is ensured that the equipment in the integrated ESS and the system are completely de-energized.

- Ensure that powered-off equipment won't be powered back on accidentally.
- Ensure that the exposed accessible parts of the interior of the equipment are completely de-energized.
- Perform necessary grounding.
- Use insulating materials with insulation class greater than 1000V to insulate and cover the adjacent potentially live parts of the running part.
- Keep the escape routes free during the entire operation.
- After the integrated ESS is completely out of operation, be sure to wait at least 10 minutes before running it.
- Make sure that the integrated ESS is within the safe voltage.
- Wear labor protection gear correctly.

2.9 Arc Protection

 **DANGER**

In order to avoid unnecessary casualties and equipment damage, the product must be operated strictly according to the description in this manual. If the operation is improper, it may cause an arc hazard, and may even cause fire, explosion and other risks. The company will not be liable for any accidents such as arcs, fires, explosions and other accidents caused by failure to operate in accordance with the signs or product manual.

Improper operation described below may cause electric arc, fire, explosion and other dangers inside the machine. Always remember that in the event of an accident, it must be dealt with by qualified professionals. Improper operation of existing accidents may cause a wider range of failures or accidents.

- Plug and unplug the DC side high-voltage cables of each device under power.
- Touch potentially live cable ends that are not insulated.
- Touch copper bars, terminals, or other parts inside the machine that may be live.
- Power line connections are loose.
- Parts such as screws accidentally dropped into the power module.

System Manual

- Improper operation by untrained and unqualified operators, etc.

Before working on the equipment, the area of operation must be pre-assessed for arc risk. If there is a risk of arcing:

- Operators must have received relevant safety training in advance.
- Try best to assess the area where shock may occur.
- Wear appropriate protective clothing before working in areas of potential electric shock.

2.10 Electrostatic Protection

CAUTION

Touching or improper handling of printed circuit boards or other static sensitive components can damage the device.

- Avoid unnecessary board contact.
- Comply with electrostatic protection regulations, such as wearing ESD wrist straps.

2.11 LCD Parameter Setting

Some settable parameters in the LCD are closely related to the operation of the integrated ESS and its internal equipment. These parameters can be modified only after a reliable analysis and evaluation of the system's running conditions.

WARNING

- Improper parameter settings may affect the normal function realization of internal devices.
- Only authorized professionals can set the parameters.

2.12 Sand and Moisture Protection

In case of sandstorms, thunderstorms, strong winds, hail and other severe weather during maintenance, or when the relative humidity of the surrounding environment is greater than 95%, do not open the cabinet door of the integrated ESS.

2.13 Body Warning Signs Protection

The warning signs on the body of the product and the internal electrical equipment contain important information for safe operation of the product and internal equipment. Tearing or damage is strictly prohibited!

ATTENTION

Never tear or damage the signs,

- Ensure body warning signs are legible at all times.
- Once the warning signs on the body are damaged or blurred, be sure to replace them immediately.

2.14 Safety Warning Sign Protection

When carrying out on-site transportation, installation, inspection, maintenance and other operations of the outdoor battery cabinet and PCS, please observe the following precautions in order to prevent unrelated personnel from approaching and causing disoperation or accidents:

- Place eye-catching warning signs on the outdoor battery cabinet and the front and rear switches of the ESS to prevent accidents caused by false closing.
- Set up warning signs or safety warning belts near the field operation area.

2.15 Transport and Inspection

Improper transportation methods may result in equipment damage or personal injury or death. The outdoor battery cabinet must be transported or moved in strict accordance with the running procedures of the transport equipment.

 **WARNING**

Only complete and undamaged outdoor battery cabinets and PCS can be installed and used!

After receiving the outdoor battery cabinet and PCS, first check whether the received equipment is complete according to the delivery list, and check whether there is any damage during transportation. If there is any damage, please contact the carrier or KSTAR immediately, and provide photos of the damage, so that we can provide you with the fastest and best service.

2.16 Installation and Commissioning

The installation and running environment of the outdoor cabinet is outdoors, and its installation location and foundation must meet the requirements. In addition, during the entire process of electrical connection, the operation must strictly follow the regulations.

 **WARNING**

The system can only be put into operation after being installed and confirmed by professionals and approved by the local power department. Please close all power distribution circuit breakers before the equipment is in operation, and it is strictly forbidden to disconnect during the operation of the machine.

 **CAUTION**

Before commissioning the system, the installation must be thoroughly and carefully checked again.

- Check installation.
- Check whether any tools or parts are left inside the equipment.
- Check system parameters.

2.17 Daily Operation and Maintenance

During daily operation, it is necessary to ensure that the doors of the integrated ESS and internal equipment cabinets are closed and locked, and the keys have been pulled out and handed over to special personnel for safekeeping in order to avoid accidents caused by unauthorized personnel entering, or internal equipment being exposed to rain, animal attack, etc. In addition, inspection and maintenance of outdoor cabinets and internal equipment should be carried out regularly to ensure long-term reliable operation of the integrated ESS.

WARNING

If related operations are carried out while the equipment is live, insulation protection must be taken, and at least two workers should be on site at the same time.

The power station where the system is located is usually located in a field environment away from the urban area, and the corresponding field rescue facilities should be prepared according to the needs, so that they can be carried out when needed.

In the process of daily operation and maintenance, also pay attention to the following items:

- Avoid checking and maintaining the equipment in the outdoor cabinet in rainy or humid weather. Ingress of moisture may damage electrical equipment.
- Each piece of electrical equipment in the outdoor cabinet has a nameplate attached to it. The nameplate contains important parameter information of the equipment, and care should be taken to protect it when performing various operations on it.
- Some equipment in the outdoor cabinet may have heat-generating components. When the equipment stops working, such components will still have a high temperature.
- Wear scald-resistant gloves when handling such devices.
- Power units and cooling fans in the integrated ESS may generate some noise during operation, and the noise will be even louder when some equipment fails. It is recommended to wear anti-noise earplugs when you are close to the outdoor cabinet.
- Comply with all installation requirements for fire suppression systems.
- If necessary, wear appropriate protective equipment, such as goggles, insulating gloves and insulating shoes, and take all necessary auxiliary measures to ensure the safety of personnel and equipment.

2.18 Product Scrapping

When the integrated ESS or internal individual equipment needs to be discarded, it shouldn't be treated as conventional waste. Some components of the internal machine can be recycled and reused, and some components will pollute the environment.

Please contact a local authorized professional recycling agency to properly dispose of the product and internal components.

3 Product Description

3.1 Product Overview

This integrated ESS produced by KSTAR is mainly used in industrial and commercial scenarios. Recommended applications are single-machine single-cabinet and single-machine dual-cabinets applications.

The integrated ESS consists of a PCS and an energy storage battery system. The ESS system integrates the PCS and system power distribution. The energy storage battery system integrates batteries, air conditioners and fire extinguishing equipment.

The protection level of the outdoor battery cabinet BC100DE is IP54, and the protection level of the KAC50DP PCS is IP65, which means that it can be installed outdoors.

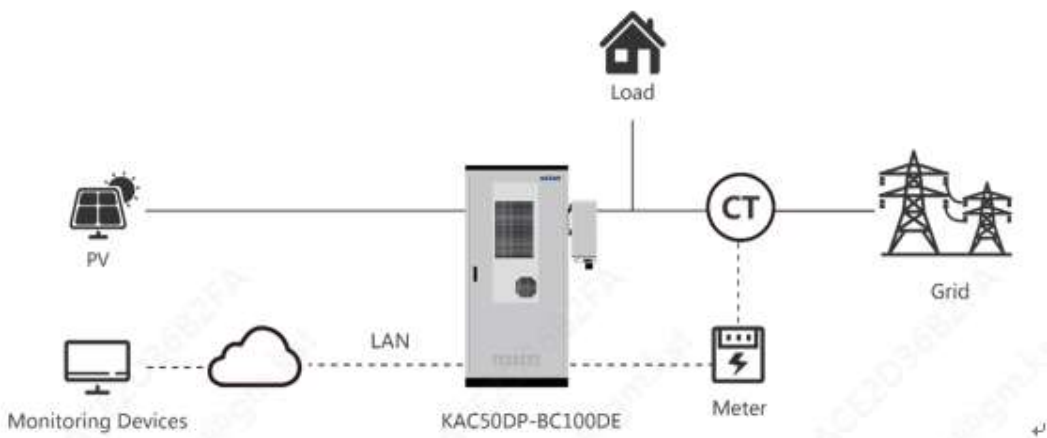

Fig. 3-1 Application diagram of ESS single machine, single cabinet, and single system

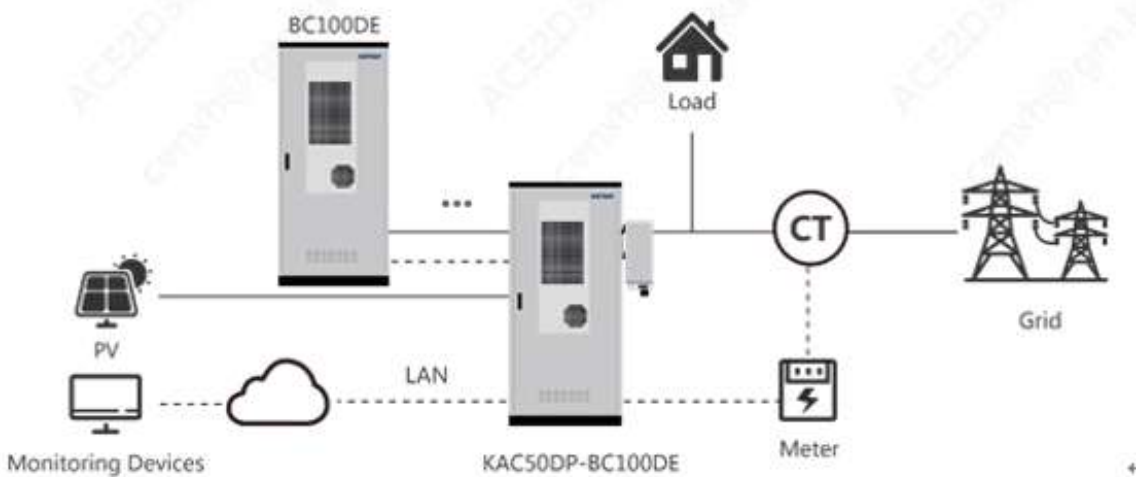

Fig. 3-2 Application diagram of ESS single machine, dual cabinets, and single system

The system includes: battery pack, BMS system, fire extinguishing system and temperature control unit, EMS, ESS and Meter.

System Manual

To facilitate system maintenance, please add a suitable distribution switch in the KAC AC and grid-connection section.

The Meter is installed at the main incoming line of the system and the grid side, and the current sampling CT direction is directed from the grid side to the system. When the meter reading is greater than 0, it means that the system, including the load, consumes electrical energy from the grid side. In order to meet the system control requirements, it is recommended to use YADA's YDS60-80 three-phase AC energy meter or other meters that can communicate with EMS. Please refer to the Meter user manual for installation requirements and setting methods. It should be noted that when using YDS60-80, the meter communication rate needs to be set to 19200 and the address must be set to 1. To ensure sampling accuracy, it is recommended to use CT with an accuracy class of 0.5 and a secondary side current of 1A or 5A.

3.2 Appearance Design

3.2.1 Appearance Introduction

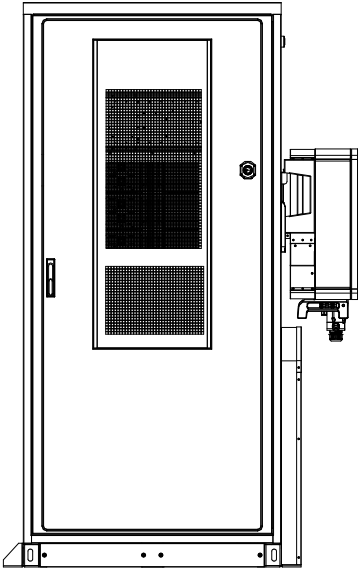

Fig. 3-2 Appearance of KAC50DP-BC100DE system

3.2.2 Mechanical Parameters

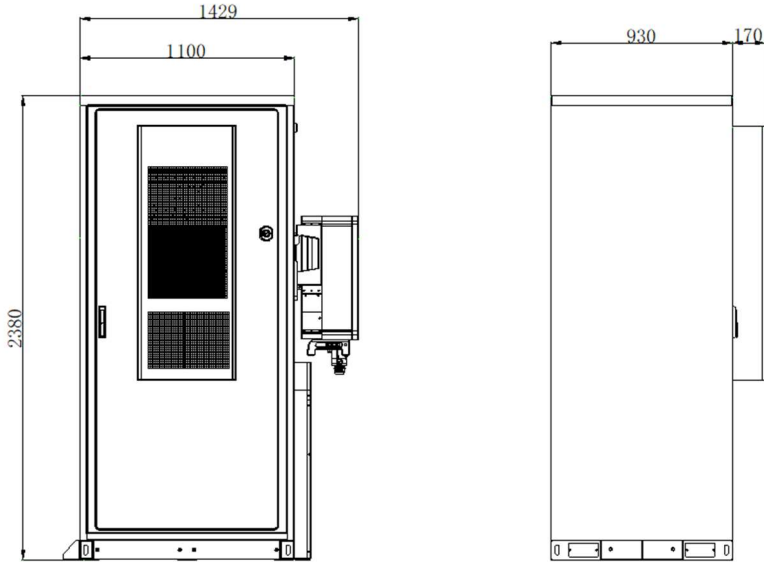

Fig. 3-3 KAC50DP-BC100DE system dimensions

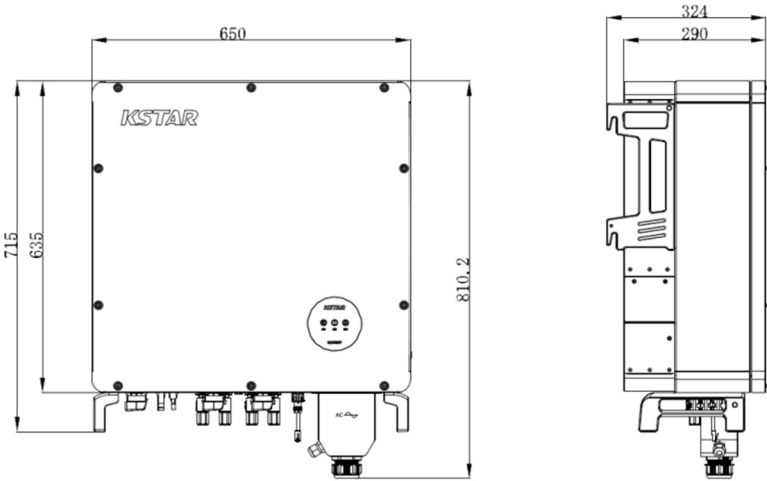

Fig. 3-4 KAC50DP PCS appearance and dimensions

3.3 System Architecture

3.3.1 System Overview

The system adopts a combined design, which combines PCS and battery cabinet into one system.



Fig. 3-5 System distribution diagram (battery cabinet on the left and single system on the right)

1	2	3	4
Battery pack	Power distribution system	Firefighting equipment	Air conditioner
5	6	7	8
EPO switch	EMS	PCS	Wire slot

3.3.1.1 Overview of the Location of Electrical Components

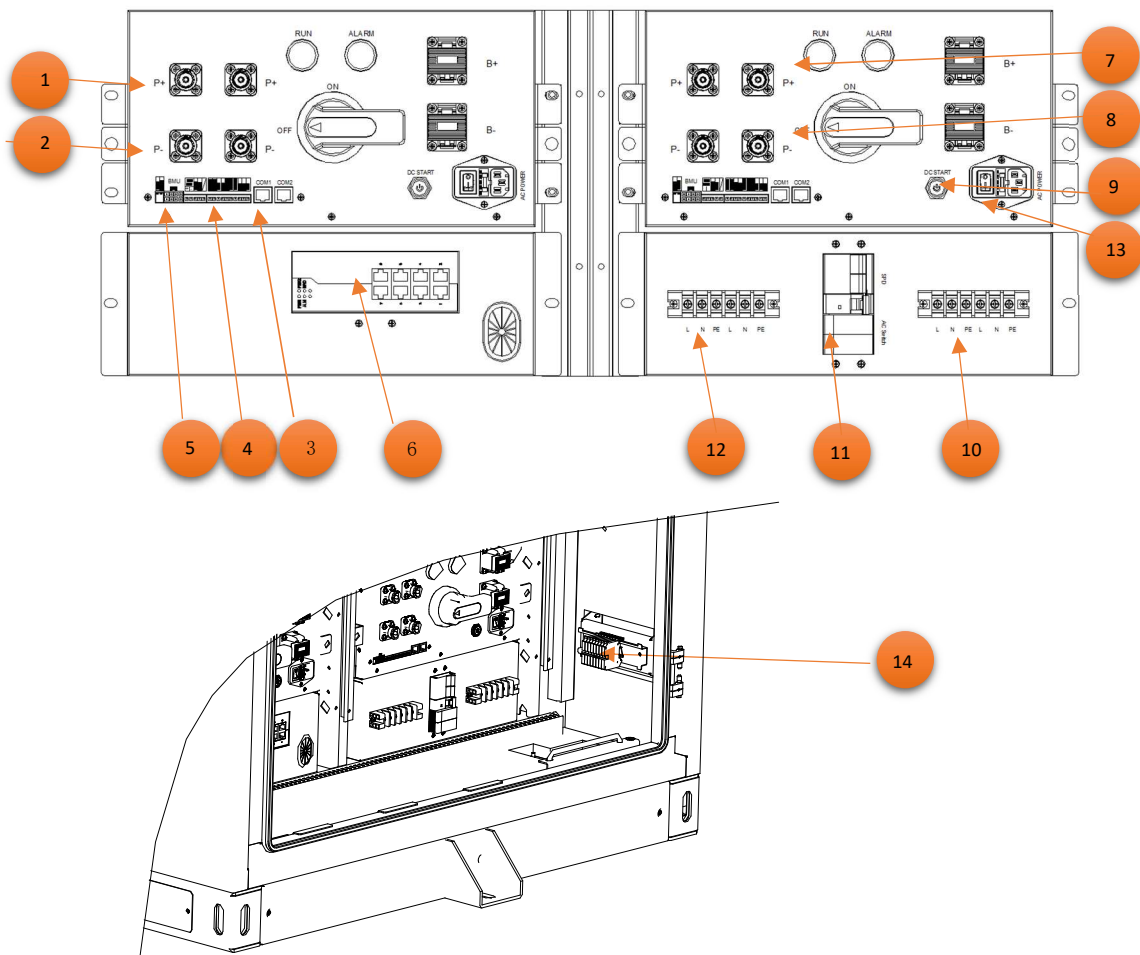

Fig. 3-8 Electrical wiring of the battery cabinet

1	2	3	4	5
DC output positive pole	DC output negative pole	Battery module information interaction port	485 port	24V power output, CAN information interaction port
6	7	8	9	10
Switch port	Positive pole of series battery	Negative pole of series battery	DC start button (black start button)	Auxiliary power input terminal
11	12	13	14	
Auxiliary power switch	A/C power supply	High voltage box power supply	External communication terminal	

3.3.1.2 Battery Module

Below is a typical system architecture for the use of iron-lithium batteries. Standardized and unitized battery modules are developed based on iron-lithium batteries. The battery modules are connected in series and equipped with switch box and distribution box to form a high-voltage battery cluster. The battery cluster is connected to the supporting PCS to form a power energy storage system product and complete the storage and release of electric energy.

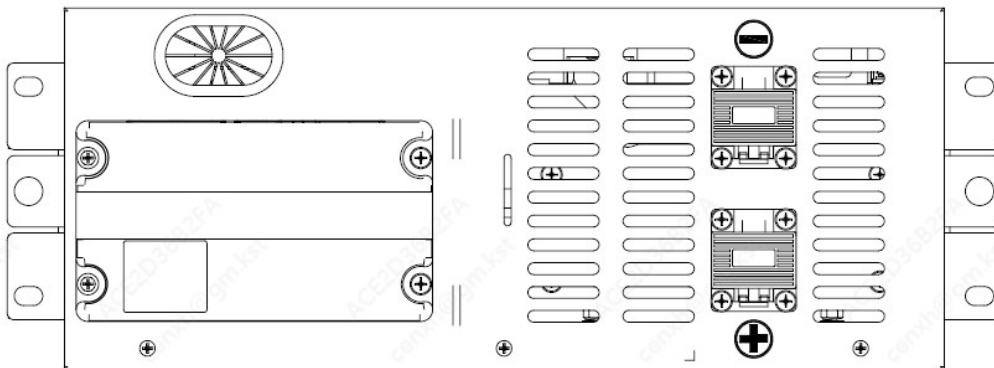



Fig. 3-9 Front view of the battery module

Note:

-  : Negative pole of the battery module;
-  : Positive pole of the battery module;

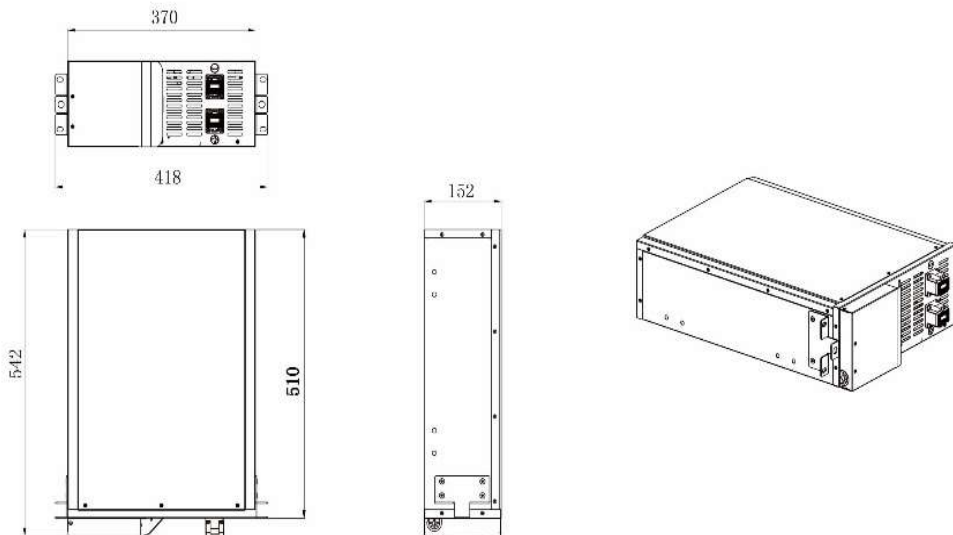

Fig. 3-10 Size of the battery module

System Manual

The iron-lithium battery module is mainly composed of batteries connected in series and parallel, and has the functions of voltage and temperature acquisition and equalization control of each battery cell. It adopts a battery management dedicated chip design, receives control commands through CAN communication, and reports the collected data.

Table 3-8 Parameters of the iron-lithium battery module

No.	Item	Characteristics
1	Series and parallel mode	16S1P
2	Rated voltage	51.2V
3	Rated capacity	100AH
4	Rated energy	5.1KWH
5	Rated charging voltage	57.6V
6	Recommended charge and discharge current	≤50A
7	Weight	About 44kg

Table 3-9 Battery cabinet parameters

No.	Item	Characteristics
1	Rated voltage	512V
2	Rated energy	51.2KWH*2
3	Rated charging voltage	576V
4	Recommended charge and discharge current	≤50A*2

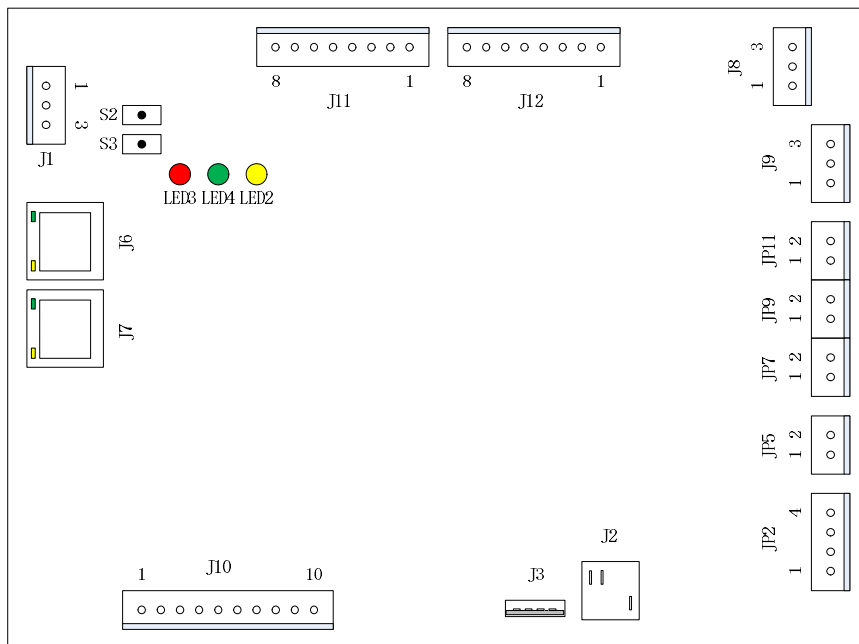

Fig. 6-6 Schematic diagram of EMS HMI interface

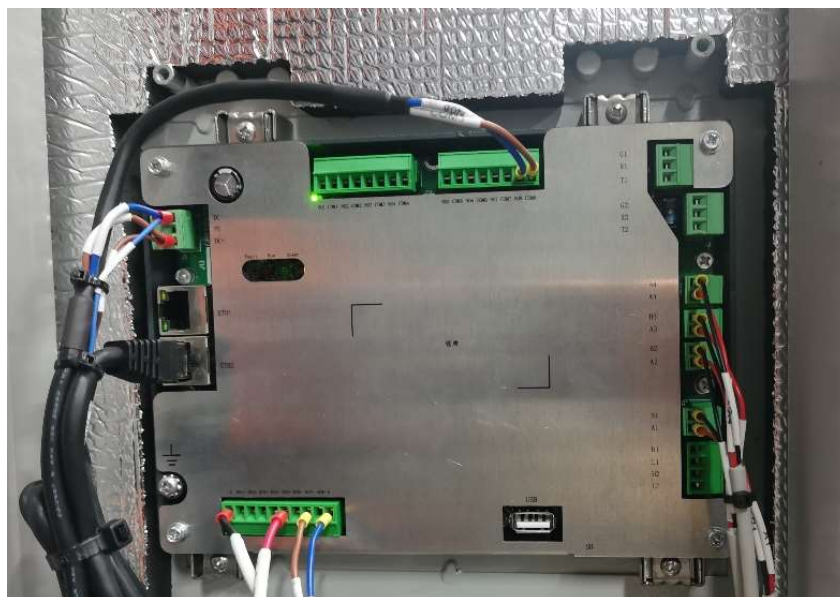

Fig. 6-7 Physical diagram of EMS-HMI interface

System Manual

Tag	Interface Name	Pin Number	Pin Definition	Pin Description	Remarks
J1	Power supply input interface	1	GND	Negative pole of power supply	Power supply range is 9-20VDC
		2	PE	GND	
		3	V+	Power supply positive pole	
J6	Ethernet port 1	/	/	/	10/100M Ethernet port (reserved)
J7	Ethernet port 2	/	/	/	10/100M Ethernet port
J10	Digital input interface	1	AGND	Digital quantity common terminal	8-channel isolated digital input detection port
		2	DI1+	Digital input channel 1 (reserved)	
		3	DI2+	Digital input channel 2 (reserved)	
		4	DI3+	Digital input channel 3 (reserved)	
		5	DI4+	Digital input channel 4 (reserved)	
		6	DI5+	Digital input channel 5 (smoke sensing signal)	
		7	DI6+	Digital input channel 6 (water immersion signal)	
		8	DI7+	Digital input channel 7 (emergency stop signal)	
		9	DI8+	Digital input channel 8 (screen calibration)	
		10	AGND	Digital quantity common terminal	
J3	USB-A standard interface	/	/	Connected to 4G network card	Supports USB 1.1 and USB 2.0 device access
J2	MICRO-SD card interface	/	/	Can be used for EMS local upgrades, etc	Support for MICRO-SD card access
JP2	CAN interface	1	L2	CAN2 differential signal L	Isolate CAN interface 1, connect to X2

System Manual

		2	H2	CAN2 differential signal H	Isolate CAN interface 2 (reserved)
		3	L1	CAN1 differential signal L	
		4	H1	CAN1 differential signal H	
JP5	RS485 interface 1	1	A1	1 RS485 signal A	Isolate RS485 interface 1, connect to X2
		2	B1	1 RS485 signal B	
JP7	RS485 interface 2	1	A2	2-channel RS485 signal A	Isolate RS485 interface 2, connect to X2
		2	B2	2-channel RS485 signal B	
JP9	RS485 interface 3	1	A3	3-channel RS485 signal A	Isolate RS485 interface 3, connect to X2
		2	B3	3-channel RS485 signal B	
JP11	RS485 interface 4	1	A4	4-channel RS485 signal A	Isolate RS485 interface 4, connect to X2
		2	B4	4-channel RS485 signal B	
J9	RS232 interface	1	TXD2	2-channel RS232 interface sending end	Isolate RS232 interface and allow for external equipment (reserved)
		2	RXD2	2-channel RS232 interface receiving end	
		3	GCOM	2-channel RS232 interface ground terminal	
J8	RS232 interface - debugging and trial use	1	TXD1	1-channel RS232 interface sending end	This isolated RS232 interface is dedicated for debugging and is not recommended for use with external devices (reserved)
		2	RXD1	1-channel RS232 interface receiving end	
		3	GCOM	1 RS232 interface ground terminal	
J12	Digital output interface 2	1	COM8	8-channel relay output common terminal (4G module enable interface)	5-channel to 8-channel relay switching output, Normally open output,

		2	NO8	8-channel relay output constant start (4G module enable interface)	Capacity 2A 30VDC/0.5A 125VAC
		3	COM7	7-channel relay output common terminal	
		4	NO7	7 relay outputs normally open	
		5	COM6	6-channel relay output common terminal	
		6	NO6	6-channel relay output normally open	
		7	COM5	5-channel relay output common terminal	
		8	NO5	5-channel relay output normally open	
J11	Digital output interface 1	1	COM4	4-channel relay output common terminal	1-channel to 4-channel relay switching output, Normally open output, Capacity 2A 30VDC/0.5A 125VAC
		2	NO4	4-channel relay output normally open	
		3	COM3	3-channel relay output common terminal	
		4	NO3	3-channel relay output normally open	
		5	COM2	2-channel relay output common terminal	
		6	NO2	2-channel relay output normally open	
		7	COM1	1 relay output common terminal	
		8	NO1	1 relay output normally open	

System Manual

S3	Restore factory button	/	/	/	Long press and hold this button for 10S to restore factory settings
S2	Reset button	/	/	/	Press this button to reset the system
LED3	Fault indicator light	/	/	/	Controllable fault indicator light
LED4	Running indicator light	/	/	/	Controllable operation indicator light
LED2	Power indicator light	/	/	/	Power indicator light

Attention: The screen needs to be calibrated on time. Short circuit DI8 and the EMS screen will restart. Follow the instructions on the screen and click the cursor to calibrate.

3.3.2 PCS

The PCS adopts advanced digital control technology, which optimizes the control function and improves the system reliability. It is suitable for charging and discharging of various batteries. It adopts modular structure design, which is convenient for installation and maintenance. The main functions are as follows:

- On-grid scheduling; RS485 communication;
- On-grid mode; Off-grid mode (STS switching cabinet needs to be configured)
- Multiple independent converters connected in parallel;
- Run at 110% of rated output power for a long time;
- AC and DC dual-input redundant power supply mode to ensure the reliability of the control power supply;
- IP65 protection level, anti-drip and anti-condensation function;
- Modular design: Maintenance at front end.

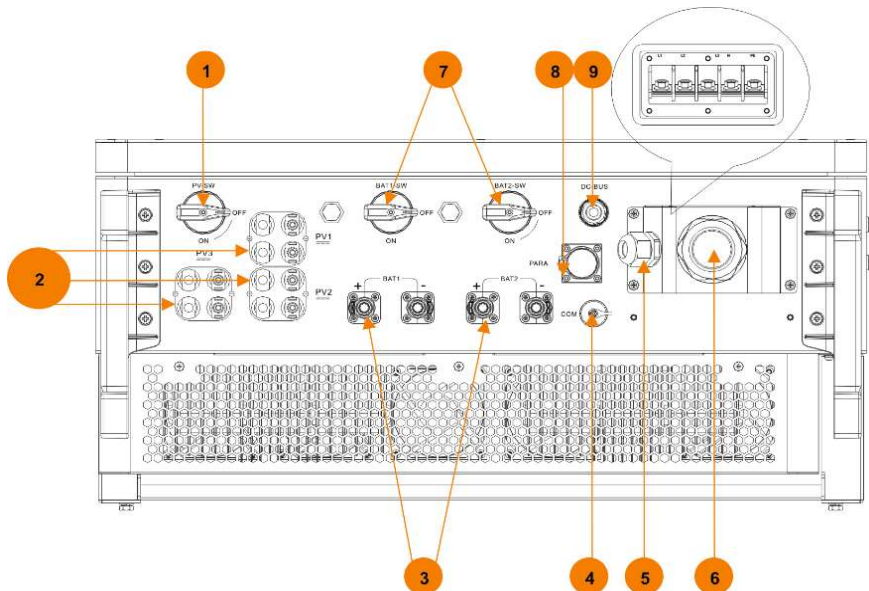

Fig. 3-7 Electrical location diagram of PCS

1	2	3	4	5
PV Switch	PV terminal	Battery terminal	Communication (CAN) interface	Battery auxiliary terminal
6	7	8	9	
AC terminal	Battery switch	Parallel (RS485) interface	Bus output interface	

4 Delivery and Storage

4.1 Scope of Supply

When the system is shipped, the battery cabinet, PCS, and are packed separately, and the shipment list is as follows:



Fig. 4-1 BC100DE delivery checklist diagram

No.	Name	Unit	Qty	Remarks
1	Battery system BC100DE	PCS	1	Standard configuration
2	User manual	PCS	1	Standard configuration
3	Certificate	PCS	1	Standard configuration
4	Warranty card	PCS	1	Standard configuration
5	Key	PCS	2	Standard configuration
6	Carton	PCS	1	Standard configuration (including iron wire duct)+enclosure
7	Desiccant	Bag	1	Standard configuration

System Manual

8	Corrugated pipe	m	3	Standard configuration
9	Wire components	Set	1	Subject to business orders
10	Fire clay	Kg	2	Standard configuration
11	Factory test report	PCS	1	Standard configuration

Table 4-1 BC100DE Supply List

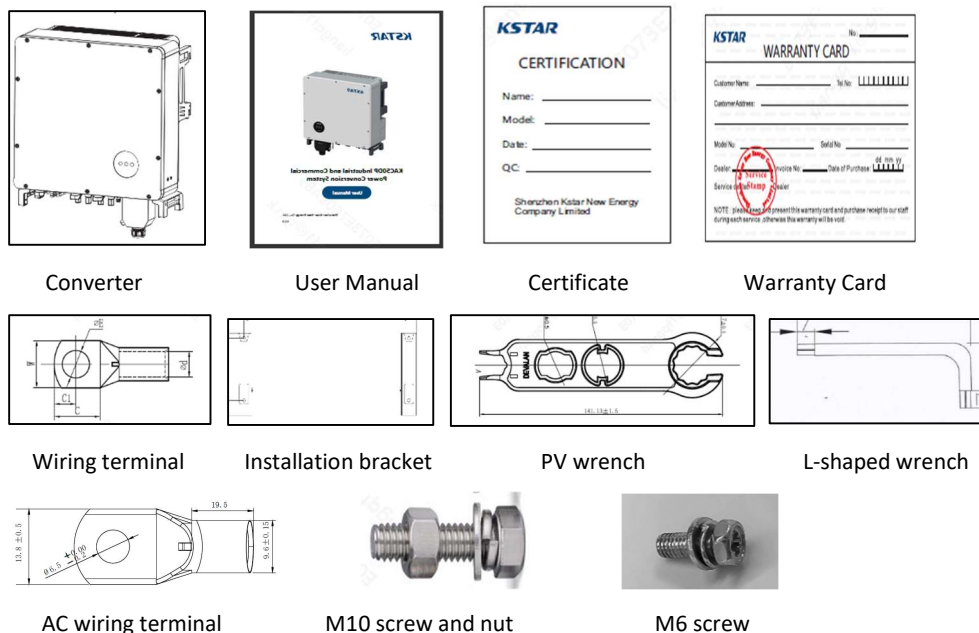

Fig. 4-2 KAC50DP delivery checklist diagram

No.	Name	Unit	Qty	Remarks
1	Converter	PCS	1	Standard configuration
2	User manual	PCS	1	Standard configuration
3	Certificate	PCS	1	Standard configuration
4	Warranty card	PCS	1	Standard configuration
5	AC terminal	PCS	5	Standard configuration
6	Installation bracket (2 installation bracket)	PCS	1	Standard configuration

	components and 1 connecting rod)			
7	Bolt (M10*35)	PCS	4	Standard configuration
8	Nut (M10)	PCS	4	Standard configuration (including iron wire slot)
9	Combination screw (M6*16)	Bag	2	Standard configuration
10	Wrench (for dismantling PV connectors)	m	1	Standard configuration
11	L-shaped wrench (for cover removal)	M	1	Standard configuration

Table 4-2 KAC50DP Supply List

4.2 Check Shipping Integrity

Before leaving the factory, the integrated ESS has been carefully inspected by our staff and packed firmly. Nevertheless, there is still a possibility that the equipment may be bumped or even damaged during transportation.

Upon receipt of the equipment, first check the integrity and soundness of the shipment. At least the following items should be carefully checked:

- Check the completeness of all delivered components against the “Scope of Delivery”.
- Confirm that the model of the integrated ESS and internal equipment received is consistent with the model you ordered before.
- Carefully check the integrated ESS and internal equipment to see if there is any damage during transportation. If any problems or doubts are found, please contact the carrier or our company in time.

WARNING

Only a complete and undamaged integrated ESS can be installed and tested! Before starting the installation make sure:

- The integrated ESS is intact.
- All equipment in the integrated ESS is intact.

4.3 Storage

- In order to prevent condensation inside the outdoor battery cabinet and PCS, or the bottom of the house is soaked by rainwater in the rainy season, the outdoor battery cabinet and PCS should be stored in an indoor environment, such as a large warehouse or in the workshop.

System Manual

- If it must be stored outdoors due to on-site conditions, the outdoor battery cabinet and the base of the ESS must be raised. The specific elevation height should be reasonably determined according to the site's geological and meteorological conditions. If the ambient temperature is too low, heating should be provided for the outdoor battery cabinet and the internal equipment of the ESS.
- Storage environment temperature: $-20^{\circ}\text{C}\sim 50^{\circ}\text{C}$; recommended long-term storage temperature: $20^{\circ}\text{C}\sim 30^{\circ}\text{C}$; storage relative humidity: $0\sim 95\%$, non-condensing.
- Store the outdoor battery cabinet and PCS on a dry, flat, firm ground with sufficient bearing capacity and without any vegetation cover. The storage ground must be flat, free of water, no bumps or undulations.
- During storage, the doors of the outdoor battery cabinet and the ESS cabinet should be locked tightly.
- During long-term storage, it should be ensured that the SOC is $\geq 50\%$ to prevent damage to the battery cells.
- SOC calibration needs to be conducted every 6 months through charging and discharging cycles.
- Please be careful not to drop or flip the battery during transportation, ensuring it is facing upwards.

5 Mechanical Installation

WARNING

During the whole process of mechanical installation, the relevant standards and requirements of the project location must be strictly followed.

5.1 Conditions of Transport

All kinds of equipment have been installed and fixed in the outdoor battery cabinet before leaving the factory, and the outdoor battery cabinet can be transported as a whole during transportation.

WARNING

During the whole process of loading, unloading and transportation, the outdoor cabinet operation safety regulations of the country/region where the project is located must be followed!

- All personnel engaged in loading, unloading and bolting should receive appropriate training, especially in safety.

ATTENTION

During the whole process of loading, unloading and transportation, it is necessary to keep in mind the mechanical parameters of the outdoor battery cabinet and PCS.

The transportation of outdoor battery cabinet and PCS must meet the following conditions:

- The door of the outdoor battery cabinet is locked.
- Select a suitable forklift according to site conditions. The selected tool must have sufficient load capacity, arm length and radius of rotation.
- Additional traction may be required if movement on slopes is required.
- Remove all obstacles that exist or may exist during the movement, such as trees, cables, etc.
- The outdoor battery cabinet should be transported and moved under good weather conditions as much as possible.
- Be sure to set up warning signs or warning tapes to prevent non-workers from entering the lifting and transporting area to avoid accidents.

5.2 Forklift Transportation

If the installation site is flat, you can use a forklift to move the outdoor battery cabinet. The bottom of the outdoor battery cabinet is equipped with fork holes specially used for forklift transportation. Move the

outdoor battery cabinet through the front fork holes. If forklift transportation is used, the following requirements shall be met:

- The forklift should be equipped with sufficient carrying capacity (at least 5 tons).
- The length of the prongs should be at least 1100mm.
- The prongs should fit into the forked sockets on the bottom of the workstation (see the figure below for the location of the pronged sockets). The pin depth inserted into the stake should be the depth of the stake, which is 1100mm.
- Transportation, moving and setting down of outdoor battery cabinet should be slow and steady. It is recommended to take a try.
- Only place the outdoor battery cabinet on a stable place. The place should drain well without any snags or bulges. The outdoor battery cabinet shall be secured by four bottom corner pieces.

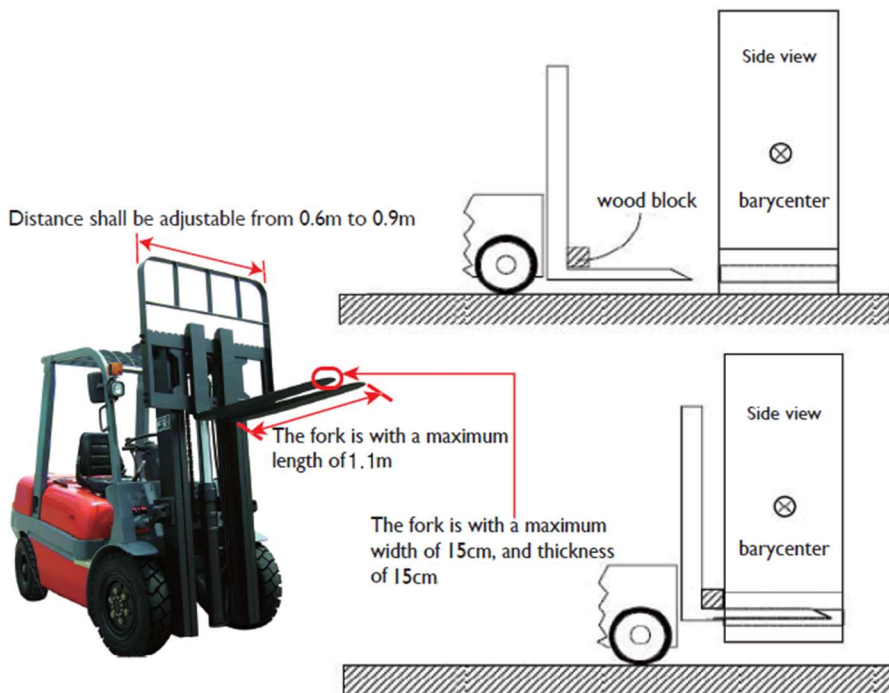

Fig. 5-1 Schematic diagram of forklift transportation

! WARNING

- Move the outdoor battery cabinet with the bottom front fork pocket.
- Under no circumstances should the outdoor battery cabinet be moved by inserting the prongs in other than the prong holes.

5.3 Building Foundation

5.3.1 Selection of Installation Site

When choosing an installation site, please consider at least the following principles:

- The climatic environment and geological conditions (such as stress wave emission, groundwater level) and other characteristics of the place where the integrated ESS is installed should be fully considered.
- The surrounding environment is dry and well ventilated, away from flammable and explosive areas.
- The soil at the installation site needs to have a certain degree of compactness. It is recommended that the relative compactness of the soil at the installation site be $\geq 98\%$. If the soil is loose, be sure to take steps to secure the foundation.

5.3.2 Foundation Requirements

WARNING

- The integrated ESS is relatively heavy as a whole. Before building the foundation, the conditions of the installation site (mainly referring to geological conditions and environmental climate conditions, etc. should be inspected in detail. Only on this basis can the design and construction of the foundation be started.

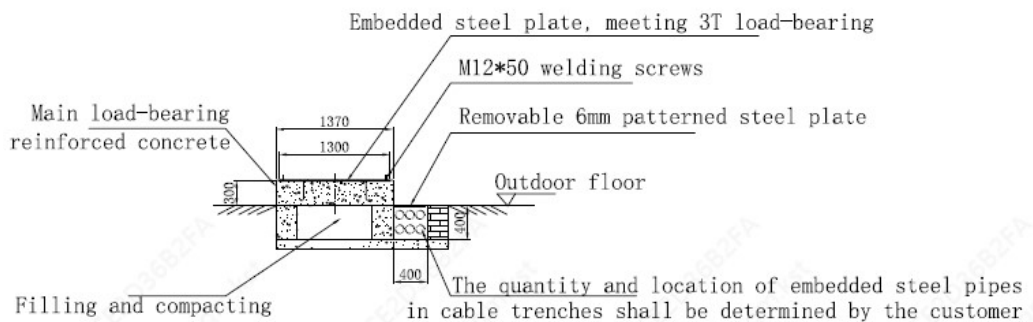

Fig. 5-2 Reference Front View of Battery Cabinet Installation Foundation

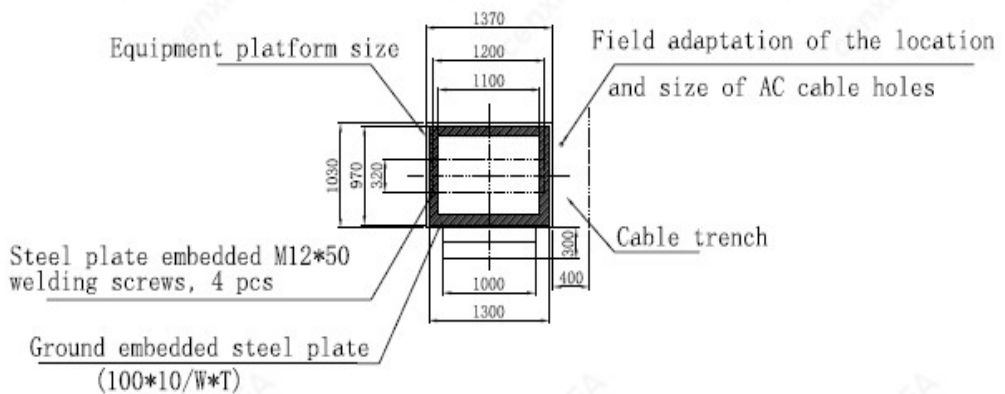

Fig. 5-3 Reference Top View of Battery Cabinet Installation Foundation

An unreasonable foundation construction plan will bring great difficulties or troubles to the placement of the integrated ESS, opening and closing doors, and later operation. Therefore, the installation foundation of the integrated ESS must be designed and constructed in advance according to certain standards to meet the requirements for mechanical support, cable routing, post-maintenance and overhaul, etc.

At least the following requirements should be met when constructing the foundation:

- The bottom of the foundation pit for building the foundation must be compacted and filled.
- The foundation should be sufficient to provide effective load-bearing support for the integrated ESS.
- Elevate the integrated ESS to prevent rainwater from eroding the base and interior. It is suggested that the foundation should be about 300mm higher than the horizontal ground of the installation site.
- It is necessary to construct corresponding drainage measures in combination with local geological conditions.
- Construct concrete foundations of sufficient cross-sectional area and height. The foundation height shall be determined by the construction party according to the site geology.
- Cable routing should be considered when constructing the foundation.
- The maintenance platform should be built around the foundation to provide convenience for later maintenance.
- According to the position and size of the cable inlet and outlet on the outdoor battery cabinet, reserve enough space for the AC/DC side cable trough and pre-embed the cable guide in the foundation construction.
- Determine the specifications and quantity of perforating tubes according to the cable model and the number of incoming and outgoing lines.
- Both ends of all pre-buried pipes are temporarily sealed to prevent impurities from entering; otherwise, it will be inconvenient to route later.

- After all cables are connected, cable entries and exits and joints should be sealed with refractory mortar or other suitable material to prevent the entry of rodents.

i Pre-embed the grounding unit according to the relevant standards of the country/region where the project is located.

5.4 Fixed Installation

After confirming that the foundation construction meets the requirements and is sufficiently dry, firm and flat, hoist the outdoor battery cabinet and PCS to the predetermined position.

Fix the outdoor battery cabinet to the foundation with fastening bolts. After fixing, the U-shaped angle steel should be treated for anti-rust, such as spraying anti-rust paint, etc. The installation distance is as shown in the figure below:

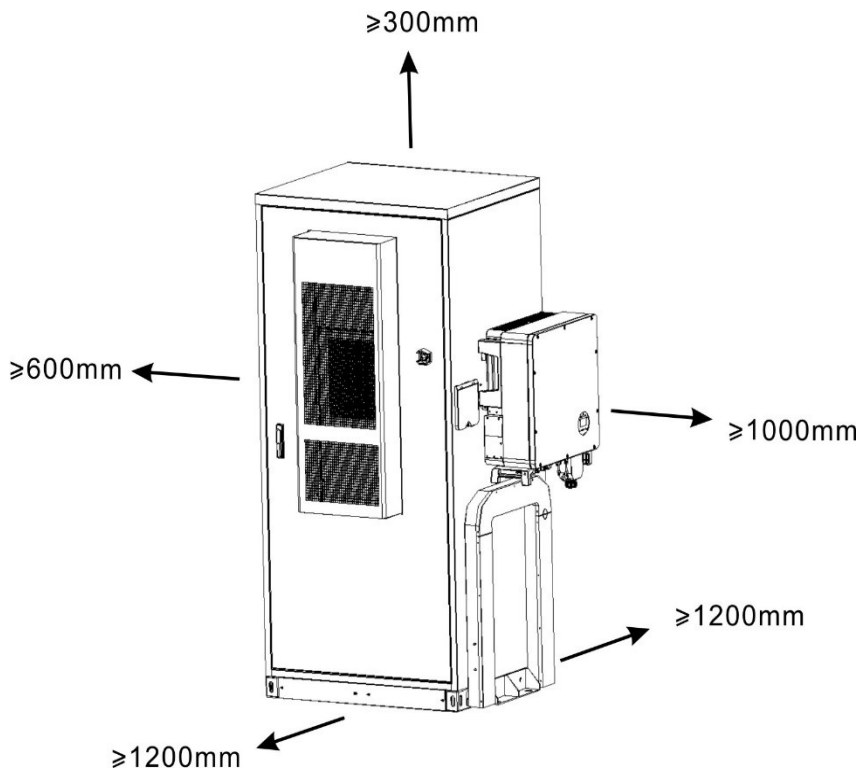

Fig. 5-1 Schematic diagram of installation space for single-machine and single-cabinet applications

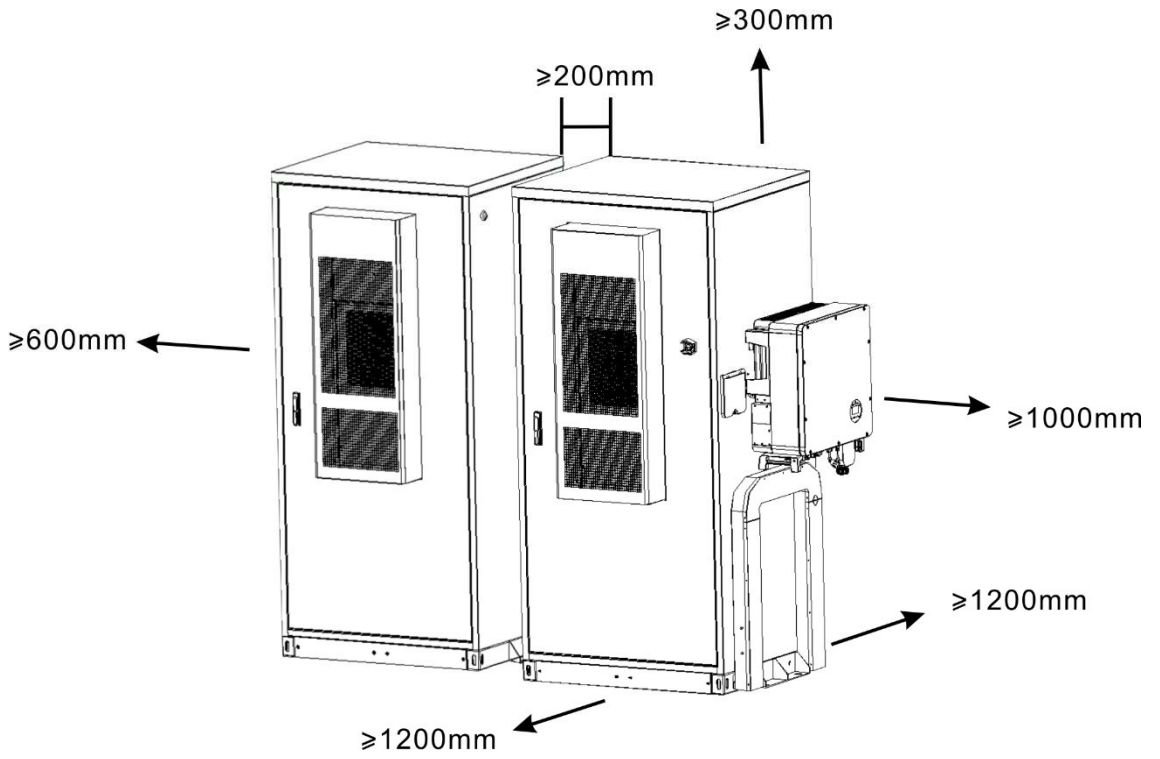

Fig. 5-2 Schematic diagram of installation space for single-machine and dual-cabinets applications

6 Electrical Connection

6.1 Safety Precautions

6.1.1 General

DANGER

Danger of high voltage! Danger of electric shock!

- Do not touch live parts!
- Please ensure that the AC and DC sides are not charged before installation.
- Do not place the integrated energy storage system on the surface of combustible materials

DANGER

When the integrated energy storage system has a ground fault, there may be a fatal high voltage in the originally uncharged part. If accidentally touched, very dangerous! Before operation, please make sure that there is no grounding fault in the system, and at the same time, you need to take relevant protective measures.

WARNING

All electrical connections must conform to the relevant standards and specifications of the country/region where the project is located.

The integrated energy storage system can only be connected to the network side after it is approved by the local power supply company and installed by professional technicians.

WARNING

Only professional electricians or qualified personnel can make electrical connection to this product.

Please strictly follow the wiring identification inside the equipment to perform wiring operation.

WARNING

Before wiring, it is necessary to disconnect the AC and DC side of the energy storage integrated system.

WARNING

- The entry of sand and moisture may damage the electrical equipment in the integrated energy storage system or affect the operation performance of the equipment!
- During the windy and dusty season, or when the relative humidity in the surrounding environment is greater than 95%, electrical connection should be avoided.
- When there is no wind and sand, and the weather is sunny and dry, then start the connection work.

⚠ WARNING

Failure to observe the torque requirements may result in fire at the connection!
During electrical connection, bolts must be tightened strictly according to the torque described in this manual.

⚠ WARNING

Only qualified electrical engineers may carry out work related to electrical connections. Please abide by the requirements given in the Safety Instructions in this manual. KSTAR shall not be liable for personal injury or property damage caused by ignoring these safety instructions.

⚠ WARNING

When laying cables, ensure electrical insulation and comply with EMC regulations. Power cables, power supply and communication cables should be laid in layers. When necessary, provide protection and support for the cables to reduce the stress them.

⚠ WARNING

Please perform wiring operations strictly according to the wiring identification inside the equipment.

ATTENTION

- The installation design of the integrated ESS must comply with the relevant standards or regulations of the country/region where the project is located.
- If the installation design requirements given in this manual are not followed, or the installation is not carried out in accordance with the relevant electrical standards or specifications of the installation location, the warranty will not cover the resulting failure of the integrated ESS or system.

6.1.2 Five Safety Rules

During the whole process of electrical connection, as well as all other operations on equipment such as integrated ESS, the following five safety rules must be observed:

- Disconnect all external connections to the integrated ESS, as well as the connection to the internal power supply of the equipment.
- Ensure disconnections won't be accidentally re-energized.
- Use a multimeter to ensure that the equipment is completely de-energized.
- Perform necessary grounding.
- For the possible live parts adjacent to the running part, use insulating cloth to insulate and cover them.

 **WARNING**

- All electrical connections must be made in strict accordance with the wiring diagram.
- All electrical connections must be made with the equipment completely de-energized.

 **WARNING**

Only qualified electrical engineers may carry out work related to electrical connections. Please abide by the requirements given in Safety Instructions in this manual. The company does not assume any responsibility for personal injury or property damage caused by ignoring these safety instructions.

ATTENTION

Caution

- The installation design of outdoor battery cabinets and PCS must comply with the relevant standards or regulations of the country/region where the project is located.
- If the installation is not carried out according to the installation design requirements given in this manual, the warranty will not cover the resulting in failure of the outdoor battery cabinet, PCS or the system.
- Please make sure that the maxes short-circuit current and max input voltage of each MPPT is within the allowable range of the converter.
- When connecting PV string and battery cables, please make sure that the polarity of the cables matches the polarity of the converter's wiring ports, if the cables are connected incorrectly, it may lead to equipment damage.

6.2 Wiring Parts

 **WARNING**

Incorrect wiring sequence may cause fire or burns. Please pay attention to the connection sequence of the wiring parts. When connecting, make sure that the connectors are tight. Insufficient connections or oxidation of the contact surfaces can also cause excessive heat, which may result in a fire.

ATTENTION

Caution

- The length of the screw should be selected properly, just slightly exposing the installation hole; if it is too long, it may affect the insulation performance of the equipment, or even cause a short circuit.
- After the installation is complete, check the connection between the wiring copper lug and the copper bar to see if any heat-shrinkable sleeve is clamped. If it is clamped, it should be removed in time, or it may cause poor contact or even damage the equipment.

Fixing screws and other parts used for power line wiring of the integrated ESS have been packed in special packaging bags when the equipment is delivered. Please connect the cables strictly according to the description in this section.



6.2.1 System Cables



According to the requirement of KAC50DP converter capacity configuration, it is recommended that the current passed on the 1mm^2 wire should not be more than 6A, and the connecting wires on the same side should be selected with the same specification and type of wires, KSTAR gives the reference requirement of various types of interfacing cables, and the length of the wires should be determined according to the on-site installation environment. Users can design the related cables according to the following table for reference. When designing cables, follow the instructions in this section and the local wiring regulations, and consider the environmental conditions, laying methods and other choices. When the control cable must pass through the power cable, make sure that the angle between the two cables is kept at 90° as far as possible.

Model capacity	AC output	Ground wire	Positive and negative DC input (per pole)	Battery cabinet AC auxiliary power input	External communication line
50KW	$\geq 25\text{ mm}^2 \times 4$	$\geq 16\text{ mm}^2$	Battery input $\geq 16\text{ mm}^2 \times 4$ PVinput $\geq 6\text{ mm}^2 \times 6$	$\geq 2.5\text{ mm}^2 \times 3$	Two core shielded twisted pair

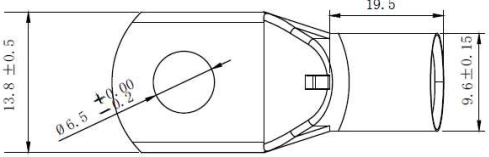
Table 6-1 KAC Converter Power line Specifications

The system interface and recommended wires cables are shown in the figures below.

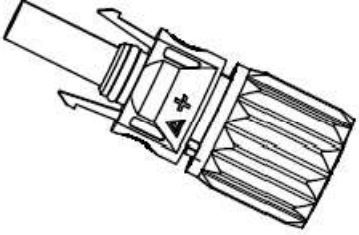
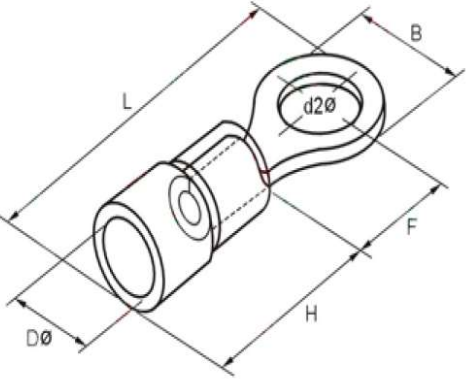
	<p>AC wiring terminal: plug-in terminal OL25-6 red copper tinned RoHS</p> <p>Suggested cables: 25mm^2 power line RoHS (450/750V)</p>
	<p>PV negative electrode connector: VP-D4B-CHSM4 black plug-in RoHS (Vaconn D4-B PV connector cable terminal, positive plastic shell and pole core)</p> <p>Suggested cables: 10AG 105°C 1000V power line</p>

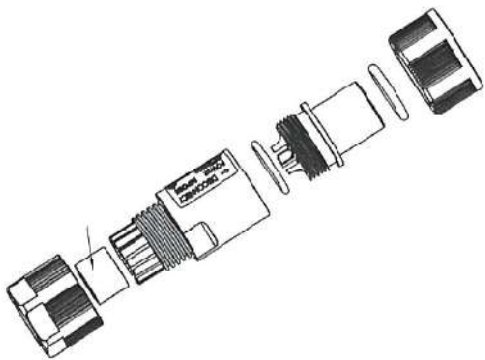
	<p>PV positive connector: VP-D4B-CHSF4 black plug-in RoHS (Vaconn D4-B PV connector cable terminal, positive plastic shell and pole core)</p> <p>Suggested cables: 10AG 105 °C 1000V power line</p>
	<p>Auxiliary power input line terminal: plug-in terminal OI5.5-5 pre insulated red copper/PVC RoHS</p> <p>Suggested cables: single line yellow green/blue/brown 60245IEC57 (YZW) 3C/2.5mm² power line RoHS</p>
	<p>Battery connector: VP-ES-SP16ABF001 black plug-in RoHS (TUV certified 1000Vdc/80A straight head connector female end 45 °, Vaconn)</p> <p>Suggested cables: 6AG 105 °C 1000V power line</p>
	<p>RS485, CAN communication terminal: EC04681-2023-BF_ A 10A/250V light green plug-in IP68 RS485 output 4-core RoHS</p> <p>Suggested cables: combination wire red black 2*(2*22AWG) twisted pair</p>

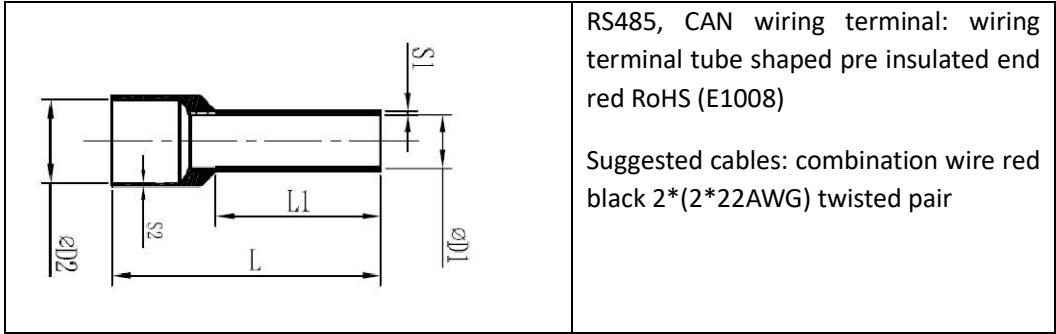

6.2.2 AC side making terminal

Follow the steps shown below to make the terminal.

Step 1: Peel off the insulation at the end of the cable. The length of the insulation at the end of the cable should be the depth of the copper lug crimping hole plus 50mm.

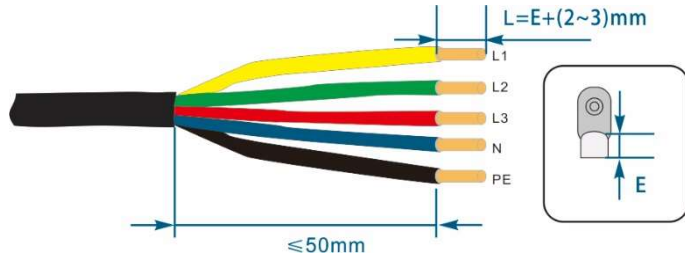

Step 2: Put the exposed copper core part of the stripped wire end into the crimping hole of the copper lug.

Step 3: Use a terminal crimping machine to compress the copper nose of the wiring, and select a heat shrinkable sleeve that matches the size of the cable, and the length should exceed the wiring copper nose crimping tube by about 2cm.

Step 4: Put the heat shrinkable sleeve on the wiring copper lug, so as to completely cover the crimping hole of the wiring copper lug.

Step 5: Shrink the heat shrinkable sleeve with a hot hair dryer.

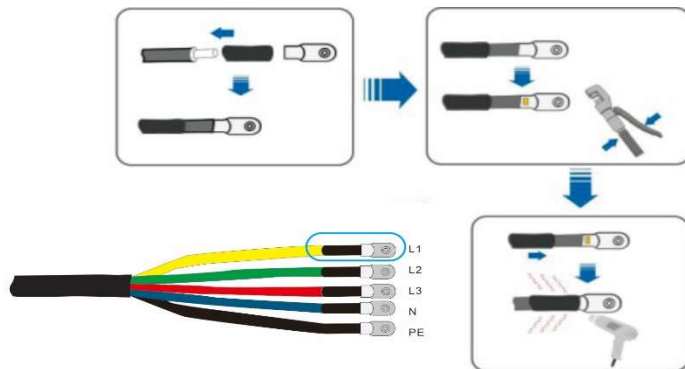

6.2.3 PV terminal making

KSTAR provides corresponding plug connectors within the delivery scope for quick connection of PV inputs. The DC cable should be connected to the inverter through a PV connector, which is included in the delivery scope.

Step 1: Strip off the insulation layer of all DC cables by about 7mm.

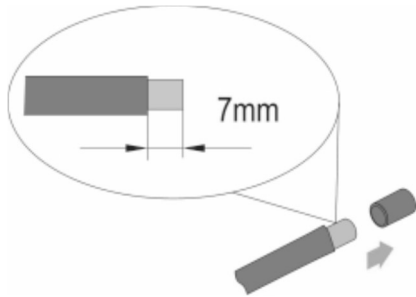

Step 2: Use crimping pliers to bundle the cable ends at the wiring terminals.

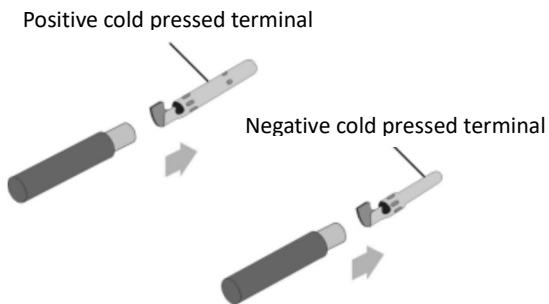

Step 3: Thread the cable through the cable gland and insert the insulation sleeve until it is securely fastened. Gently pull the cable to ensure it is securely connected. Tighten the sealing sleeve and insulation sleeve with a force of 2.5~3N•m.

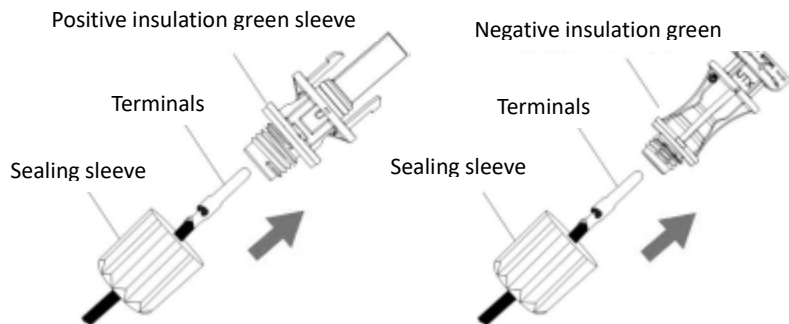

6.2.4 Auxiliary power input line terminals making

KSTAR has provided cables for auxiliary power supply within the delivery scope. To prevent insufficient wiring length due to different application scenarios. The corresponding wiring is done as shown in the following steps:

Step 1: Peel off the insulation layer of the cable.

Step 2: Use crimping pliers to bundle the cable ends at the wiring terminals.

Step 3: Place the heat shrink sleeve over the copper nose of the wiring to fully cover the crimping hole of the copper nose.

Step 4: Use a hot hair dryer to tighten the heat shrink sleeve.

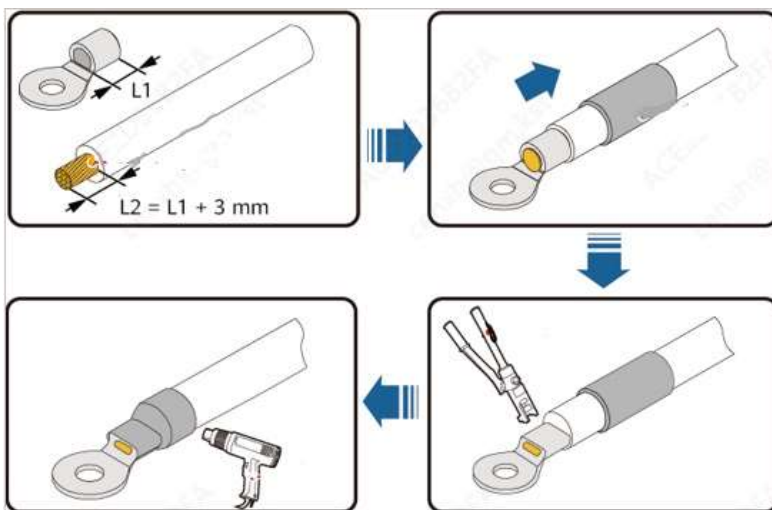

6.2.5 Battery connection wire terminals making

Step 1: Peel off the insulation layer of the cable.

Step 2: Use crimping pliers to bundle the cable ends at the wiring terminals.

Step 3: Push the insulation waterproof pad onto the crimped part of the terminal.

Step 4: Tighten the confinement components.

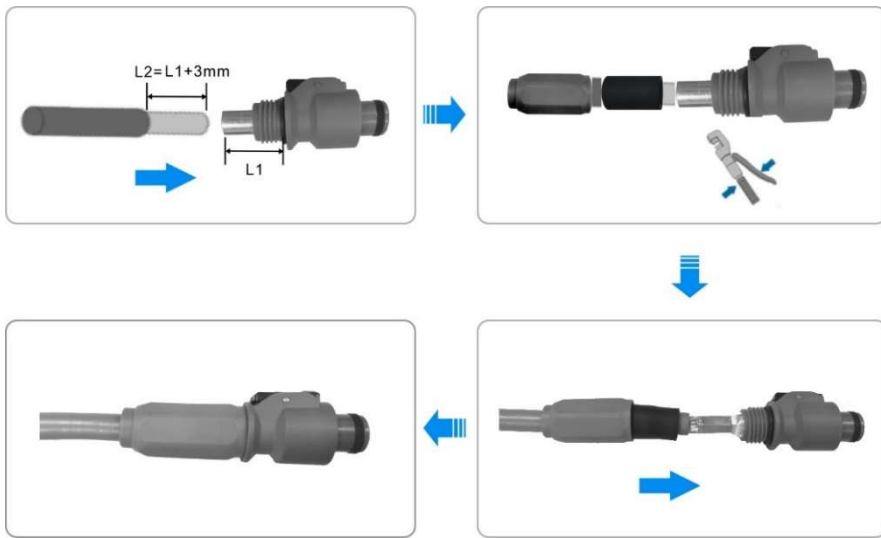

6.3 Electrical Wiring Preparation

Before delivery, the cable connection between the internal equipment of the integrated ESS has been completed. Please refer to the industrial and commercial system installation process animation for the connection between devices.

6.3.1 Tools for Installation

Before installation, you need to prepare at least the following tools and parts:

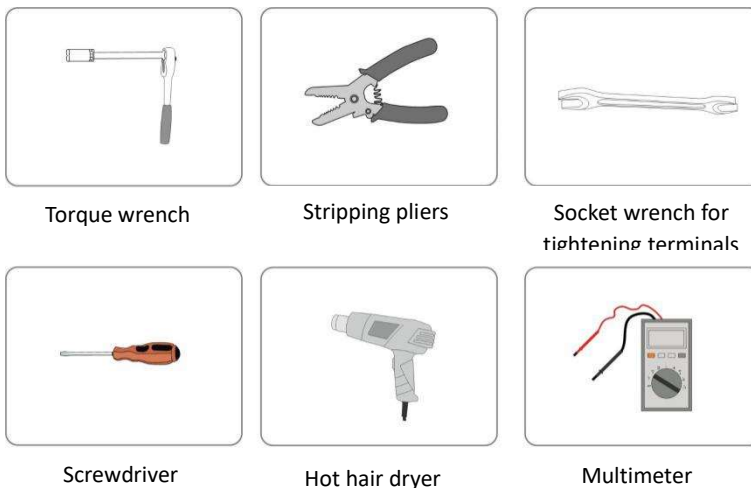

Fig. 6-3 Tools for installation

6.3.2 Checking Cables

WARNING

Before making electrical connections, check to ensure the integrity and insulation of all wires. If there is a damaged cable, please replace it in time. Poor insulation or damaged cables can be dangerous.

The wiring work between the internal equipment of the integrated ESS has been completed before leaving the factory. Users need to:

- Check whether the connecting cable is damaged. If yes, replace it with a cable of the same specification immediately.
- Check whether cable connections are securely in place. Make sure all terminals are fastened.

Refer to the internal wiring diagram of the integrated ESS and the terminal markings inside the equipment for wiring.

6.3.3 Precautions when Wiring

WARNING

- Before wiring, check the polarity of all input cables to ensure that the polarity of each input is correct.
- During the electrical installation, do not pull the cables or conductors hard to avoid damage to their insulation.
- All cables and wires should have a certain bending space.
- Take necessary auxiliary measures to reduce the stress on the cables or conductors.
- After each step of wiring operation, it is necessary to check carefully to ensure that the wiring is correct and firm.

6.4 Earth Connection

6.4.1 Introduction

WARNING

Earth connection must comply with the earthing standards and codes of the country/region where the project is located.

⚠ WARNING

The ground wire must be well grounded! If not:

- Fatal electric shock may occur in the event of a malfunction!
- Lightning can damage the equipment!
- The equipment may not function properly!

ATTENTION

During grounding, please note that:

- The ground connection between the equipment and the ground electrode must be securely fixed.

6.4.2 Equipotential Bonding of Internal Devices

Before leaving the factory, the wiring of the main electrical equipment inside the outdoor battery cabinet and the PCS to the earthing terminal has been completed. The connection of the outdoor battery cabinet and the PCS to the earth needs to be completed on site, and the following operations need to be performed on site:

- Ensure the validity of each internal earth connection by measuring the conductivity from the earth terminal of each device to the common earth copper bar.
- The shielding layer and protective layer of the cables connected externally to the outdoor battery cabinet and the ESS should also be grounded at a suitable location for the outdoor battery cabinet and the PCS.

6.4.3 External Earthing

⚠ WARNING

Connect the cables strictly according to the wiring marks inside the equipment.

The outdoor battery cabinet and PCS include internal earthing and external earthing.

Before delivery, the earthing of the outdoor battery cabinet and the internal equipment of the PCS has been completed.

Please install the external earth according to the actual situation of the project site and follow the instructions of the power station staff.

The earth resistance must be measured after the earth connection has been completed.



The earth resistance value also needs to refer to the relevant standards of the country/region where the project is located.

WARNING

During the earth connection process, if you have any questions, please contact the relevant staff in time. Failure to follow the installation specifications, or unauthorized installation or modification may lead to safety accidents or equipment damage. KSTAR shall not be liable for any losses caused thereby.

6.5 System Wiring

6.5.1 Safety Precautions

- Before wiring, the AC side cable should be measured to confirm that the AC side power grid has been disconnected to prevent the risk of electric shock.
- Check for ground faults on the battery side.
- Before connecting the DC line, turn the handle of the high-voltage DC circuit breaker in the battery cabinet to the "ON" position, press and hold the cold start button "DC START" for 3 seconds to close the high voltage of the battery, measure the open circuit voltage of the high voltage box P+ and P -, and the total voltage of the battery should be between 400V and 576V.
- Turn the handle of the high-voltage DC circuit breaker in the battery cabinet to the "OFF" position, disconnect the high voltage of the battery, and then connect the wires.
- Identify the positive and negative poles of the cable and connect the battery clusters BAT1 and BAT2 to the corresponding battery terminals of KAC, otherwise logical errors may occur during operation.
- When connecting communication cables, please use shielded twisted pair cables.

WARNING

- The open-circuit voltage on the battery side shouldn't exceed the maximum DC input voltage of the PCS. Excessively high open-circuit voltage on the battery side may cause damage to the PCS.
- When a ground fault is found on the battery side, the fault must be eliminated before wiring the DC input terminal of the PCS.

WARNING

Please perform wiring operations strictly according to the wiring identification inside the equipment.

WARNING

Follow all safety regulations listed by the manufacturer of the battery on site.

Only after all inspections and measurements are completed and the relevant parameters meet the requirements can the DC side wiring be started.

6.5.2 Wiring Overview

Schematic diagram of PCS wiring and battery cabinet wiring panel:

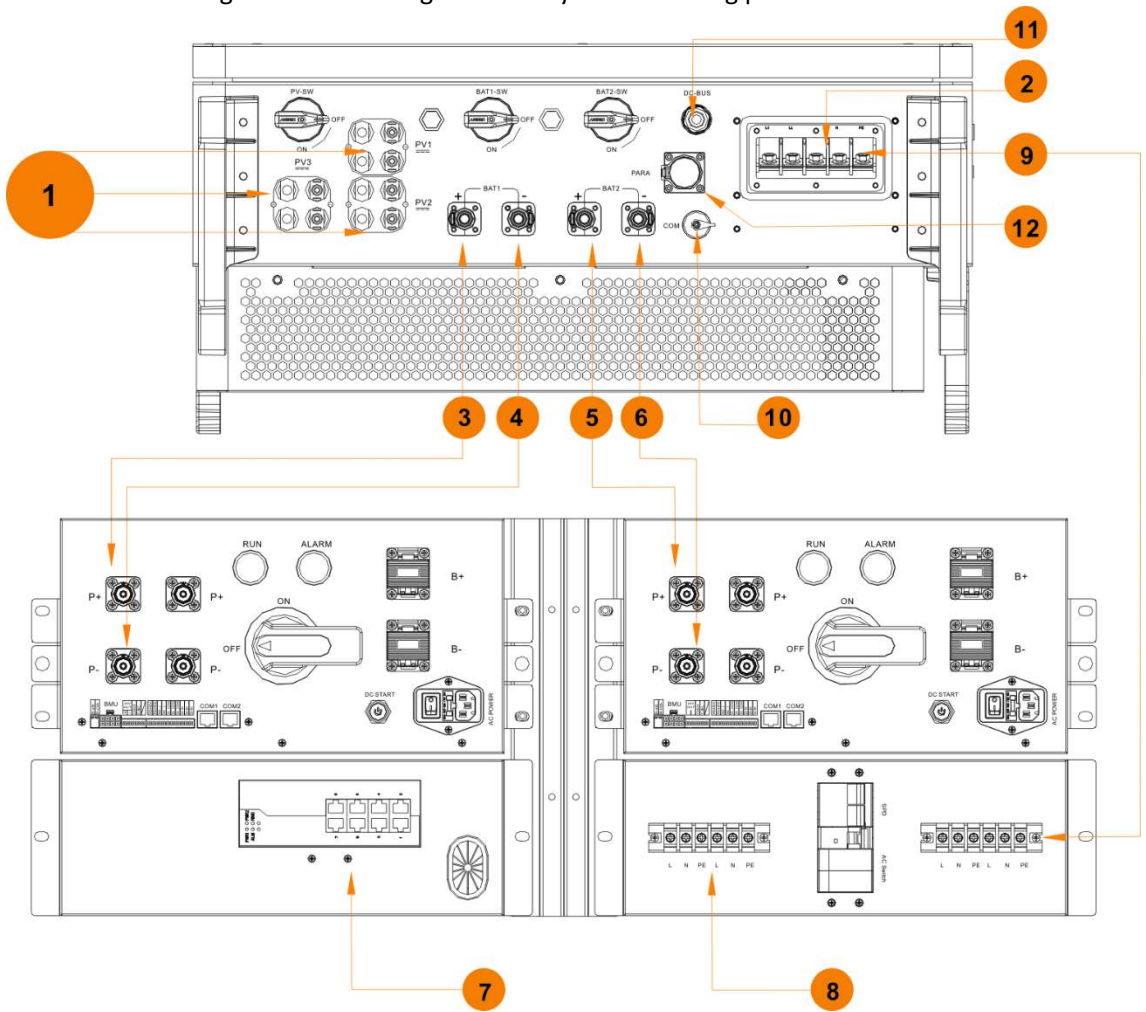

1	2	3	4	5	6
Connect to PV module	Connect to grid	Positive connection of battery 1	Negative connection of battery 1	Positive connection of battery 2	Negative connection of battery 2
7	8	9	10	11	12
Connect to EMS and BMS	A/C connection	Auxiliary power supply	Communication connection to battery terminal block	Bus output interface (reserved, STS cabinet auxiliary power supply)	Parallel interface (when there is no STS cabinet, the 1,2PIN is connected to the battery cabinet X2:485; when there is an STS cabinet, it is connected to the STS cabinet)

Fig. 6-4 Single system wiring diagram

6.6 Battery Auxiliary Wiring Steps

Step 1: Confirm that the AC Switch is in the OFF state.

Note: The AC input is 220VAC single-phase alternating current. Please confirm whether it is a non-live operation before wiring.

Step 2: Connect the L/N/PE wires of the single-phase 220VAC mains power line to the corresponding terminals according to the marks in the figure below, and fasten them with bolts (torque ≤ 2 N.M).

Note: The 3 terminals on the right side of the “INPUT” end are reserved AC input terminals, which can be used for AC power transfer. The two groups of terminals at the “OUTPUT” end are used for internal wiring such as the high voltage box and the AC power supply of the air conditioner.

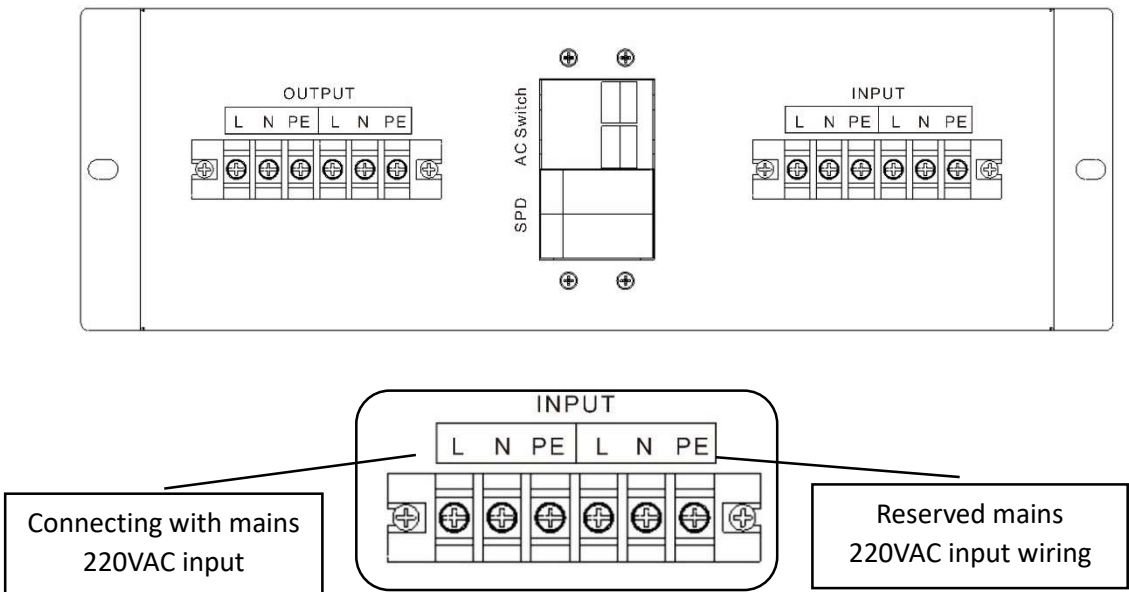

Fig. 6-5 Mains AC input connection

ATTENTION

The length of the wiring screw should be appropriate, just slightly exposing the installation hole of the copper bar. If it is too long, it may affect the insulation performance or even cause short circuit.

Check whether part of the heat-shrinkable sleeve is clamped at the connection between the wiring copper lug and the copper bar. If it is clamped, it should be removed immediately, or it may cause poor contact or even heat damage.

6.7 Communication Interface Wiring

1) Network communication interface wiring

The battery cabinet has a built-in switch, which has been connected to the network port of the EMS controller. The user needs to connect to the cloud platform or the upper monitoring system, and directly connect to the switch through a standard network cable;

2) PCS communication wiring

The EMS and KAC communication lines have been led out to the X2 terminal block, connected through the two-core signal cable as shown in the figure below, and the other end is connected to the converter communication and parallel interface:

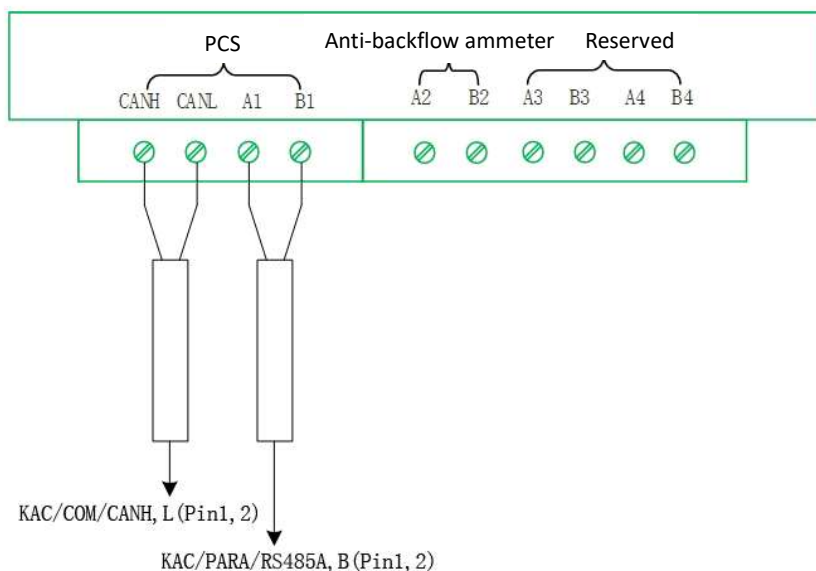

3) Anti-backflow ammeter communication wiring

The communication line between EMS and the meter has been led out to the X2 terminal and connected through a two-core signal cable as shown in the figure below, with the other end connected to the meter communication port.

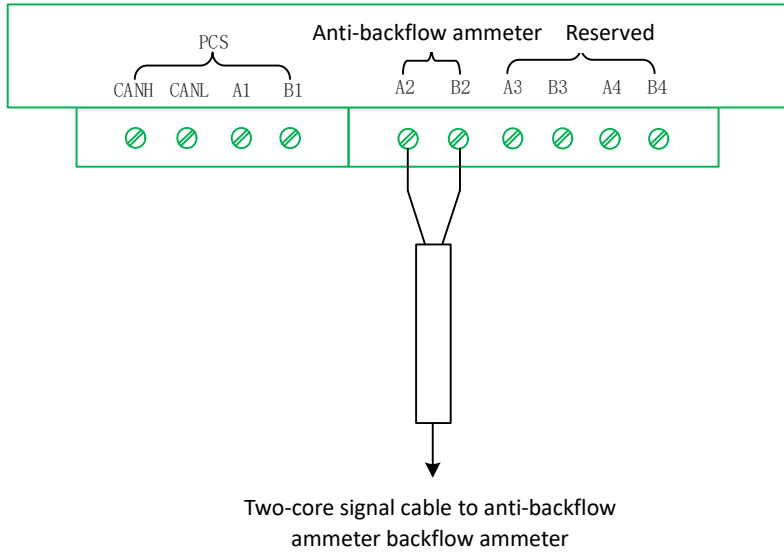

Two-core signal cable to anti-backflow ammeter backflow ammeter

6.8 Wiring and Waterproof Treatment

According to the design of the inlet and outlet holes of the outdoor battery cabinet and the base of the PCS, the cables must be laid in the space between the outdoor battery cabinet and the PCS, and led into each device through the inlet and outlet holes on the side of the cabinet. In addition, the appropriate cables should be selected according to the requirements of the outdoor battery cabinet and the equipment inside the PCS. When wiring, ensure electrical insulation and comply with EMC regulations. Power cables, power supply and communication cables should be laid in different layers. When necessary, provide protection and support for the cables to reduce the stress.

After confirming that all wiring is correct and firm, the gap between the outdoor battery cabinet and the side cable inlet and outlet holes of the PCS must be sealed with bricks or fire clay. The battery outdoor cabinet and the installation foundation of the PCS also need to be waterproofed as a whole.

6.9 Closing Electrical Connections

WARNING

After the electrical connection is completed, it is necessary to check the connection of all cables and make sure they are correct and tight.

After making all electrical connections, a thorough and careful inspection of the wiring should be performed.

- It is necessary to effectively protect the side of the outdoor battery cabinet and the PCS. For example, use fire clay to block the cable gaps.
- If waterproof terminals are used for sealing, you need to check whether the waterproof terminals are tight.
- The unused terminals shall be sealed.
- Restore all protective nets securely.
- The foundation at the bottom of the outdoor battery cabinet needs to be waterproofed.

7 Battery Description

7.1 Battery Connection

7.1.1 Introduction

An electrical connection consists of three parts:

- Power cable connections between batteries and between batteries and switchgear.
- Communication cable connections between batteries.
- Communication cable connections between battery racks.

7.1.2 Power Cord Connection

For the specific connection method, please refer to the abovementioned electrical connection.



WARNING

Connect the battery modules strictly according to the polarity. Otherwise it will cause short circuit of the battery.

7.1.3 Communication Cable Connection

For specific connection methods, please refer to the system wiring diagram and battery user manual supplied with the equipment.

7.2 Commissioning

For commissioning of the battery, refer to the relevant manual supplied with the equipment, or contact KSTAR sales or service personnel.

8 Power On/Off Operation

8.1 Check before Power-on

The check items and acceptance standards before power-on are shown in the table below:

NO.	Check items	Acceptance criteria
1	Energy storage equipment is installed in place	Installed correctly and securely and reliably
2	The cable layout is reasonable	The wiring is reasonable and meets the requirements of users
3	Cable ties are beautiful to lash	The cable tie should be uniform and cut short without leaving sharp corners
4	Reliable grounding	The ground wire connection is correct and reliable
5	Disconnect the switch	All switches are in the open state
6	Cable connections into place	AC output line, DC input line, signal line are connected correctly and firmly and reliably
7	Seal unused terminals and interfaces	Unused terminals and connections are covered with waterproof covers
8	The installation environment meets the requirements	The installation space is reasonable, the installation environment is clean and tidy, and there are no construction residues

8.2 Power-on Operation

Power-on sequence:

Step 1: After the PCS is connected to the AC power first, the internal auxiliary power supplies normally;

Step 2: Close the "AC Switch" in the battery cabinet;

Step 3: Close the "AC POWER" rocker switch of the high voltage box; After the AC auxiliary power supply in the battery cluster is working, the EMS communicates with the battery and the PCS;

Step 4: Turn the DC circuit breaker switch handle of the high-voltage box of the two clusters of batteries in the battery cabinet to the "ON" position, and the green light of the high-voltage box indicator is always on;

Step 5: Confirm that the air conditioner status and related parameter setting functions are normal;

Step 6: Close the cabinet door;

Step 7: Turn the BAT1-SW and BAT2-SW at the bottom of the KAC50DP to the "ON" position;

Step 8: Check the parameters of the EMS display on the right side of the battery cabinet are normal, and whether there is any fault;

System Manual

Step 9: Set various parameter steps, see Appendix 14.3 for details.

Step 10: Check whether the parameters of the system are normal and whether the soft start of the PCS is successful;

Step 11: Click the power on button on the screen, the power on is completed, the system is running normally, and the KAC indicator light remains green. After starting up, please check the system operation data and whether the status of each device is normal.

----Finish

8.3 Power-off Operation

Step 1: First control the cloud platform or touch screen interface to shut down the system;

Step 2: Turn the handle of the DC circuit breaker switch in the high-voltage box of the two clusters of batteries in the battery cabinet to the "OFF" position to disconnect the high voltage of the batteries;

Step 3: Disconnect the "AC Switch" switch inside the battery cabinet.

Step 4: Disconnect all switches of the KAC: Operate the main circuit AC switch to disconnect, and all indicator lights in the system will turn off.

After that, the system is powered off.

9 LCD Operation

This chapter introduces the content distribution and operation methods of the LCD interface, etc.

9.1 LCD Screen Position

The LCD touch screen is located in the battery system, basically level with the line of sight, which is convenient for users to view data and perform related operations.

Users can view and set relevant data information by touching the icon buttons on the screen.

9.2 Backlight Function

If the user does not perform any operation on the LCD within a certain period of time, then

- If there is no operation for 5 minutes, the LCD backlight turns off.
- When the user performs any operation, the LCD backlight will light up.



In order to facilitate the user to operate the LCD, this chapter provides a lot of pictures of the LCD interface. The parameter values and other specific details in the pictures are for illustration purposes only. The user should refer to the actual LCD display of the product received.

9.3 Start Page

When the system is powered on, the LCD will start automatically, and then display the homepage, as shown below. The open screen password is: 000000.

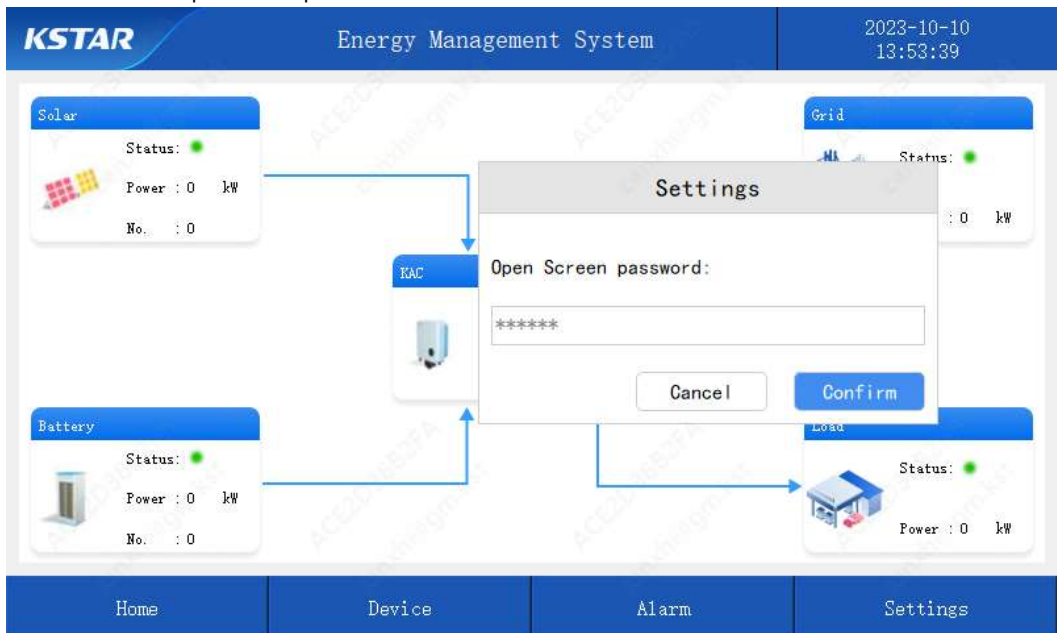

Fig. 9-1 Start page

After unlocking the screen, you can see the system homepage, which is mainly divided into four functional menus: home parameters, device, alarm, and settings.

For the convenience of expression, when referring to the homepage in the following text, it refers to this page. The descriptions of various operations and the entry of submenus at all levels also start from the homepage.

WARNING

CD screen contains a large number of parameters related to system operation. All settings such as modification of parameters must be completed by designated professionals. For parameters whose meaning is unclear, do not modify without authorization.

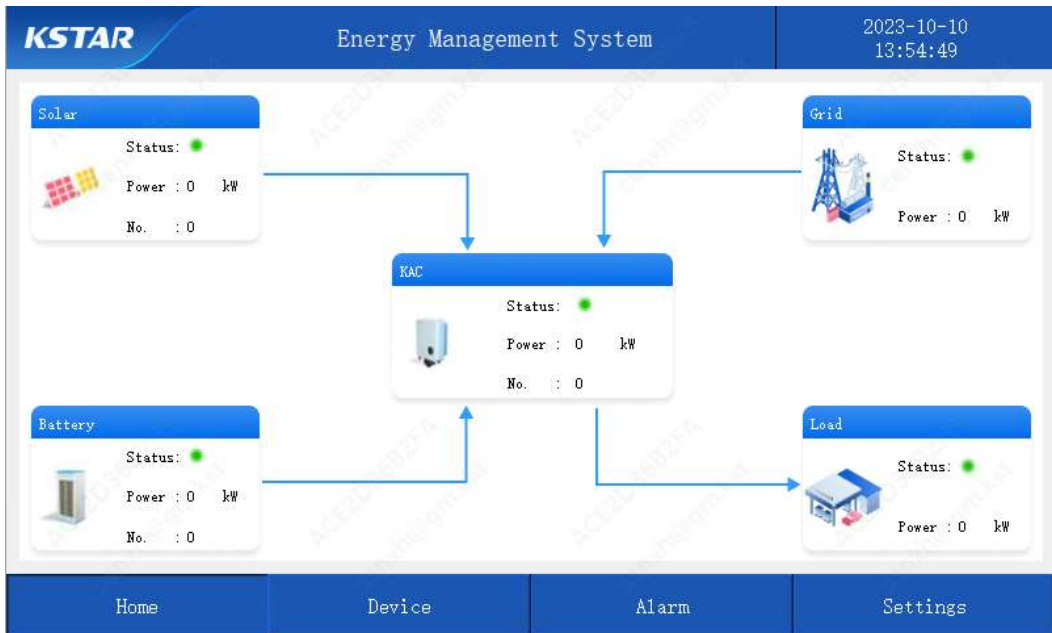

Fig. 9-2 System Homepage

9.4 Device Information Page

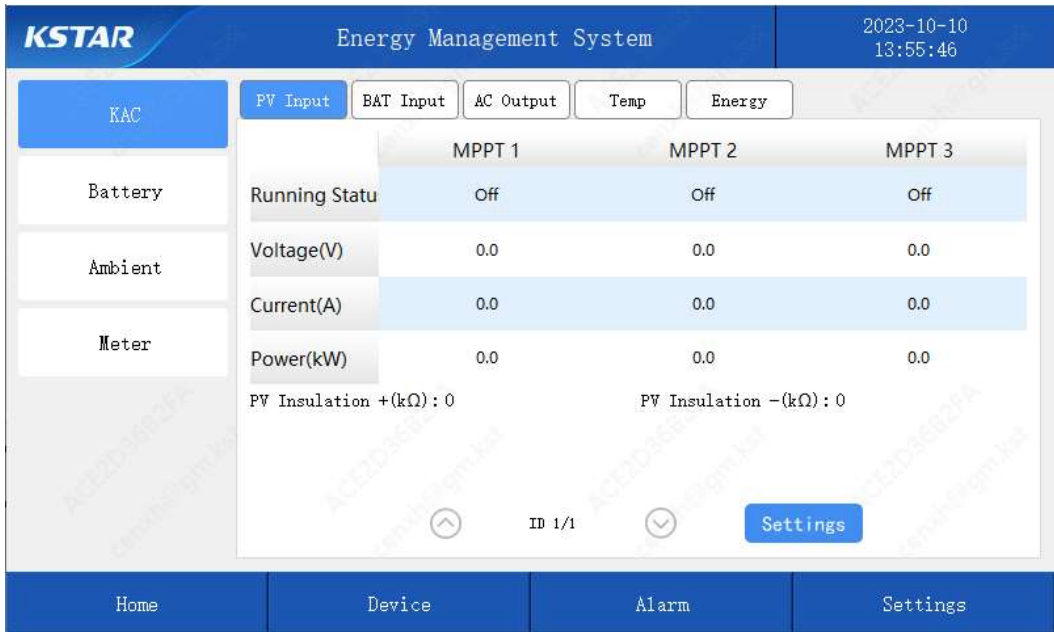

Fig. 9-3 Device Page

The system device includes converter KAC, battery, and Meter. The device page displays the parameters of various components in the system, describes the running status, and sets the device parameters.

9.4.1 Device-KAC Page

Click the on-screen device menu bar to enter the device information page. On the KAC equipment page, you can view the operation information of the PCS. It mainly includes PV operation information, battery operation information (the information is the battery port BAT1, BAT2 information detected by KAC, non-energy storage battery information, please note the difference), converter information, KAC internal area temperature information, and KAC charge and discharge statistics.

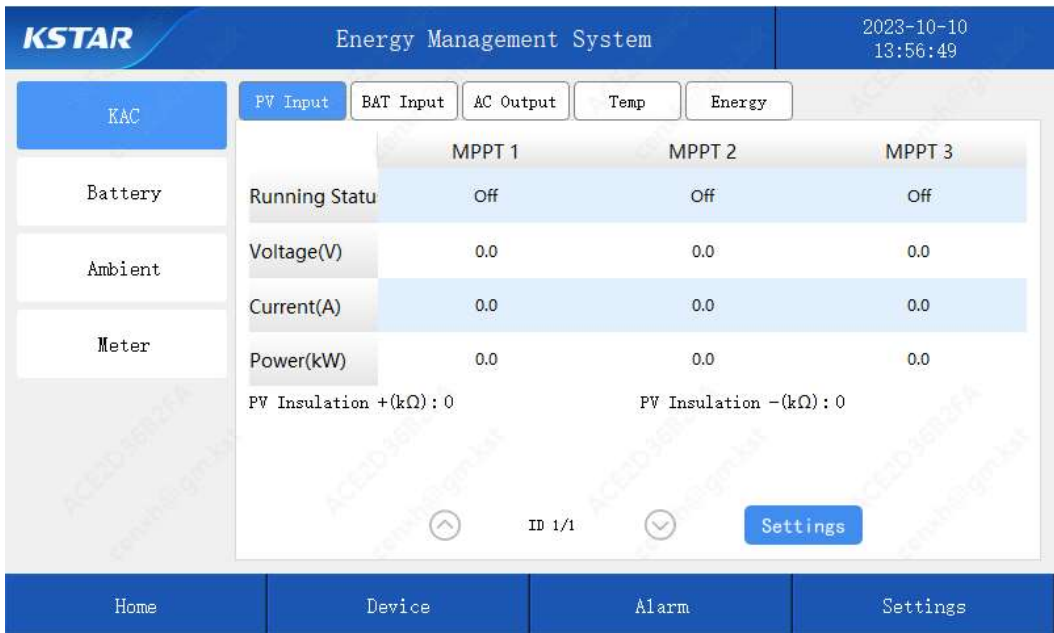

Fig. 9-4 Device-KAC-PV Operation Information Page

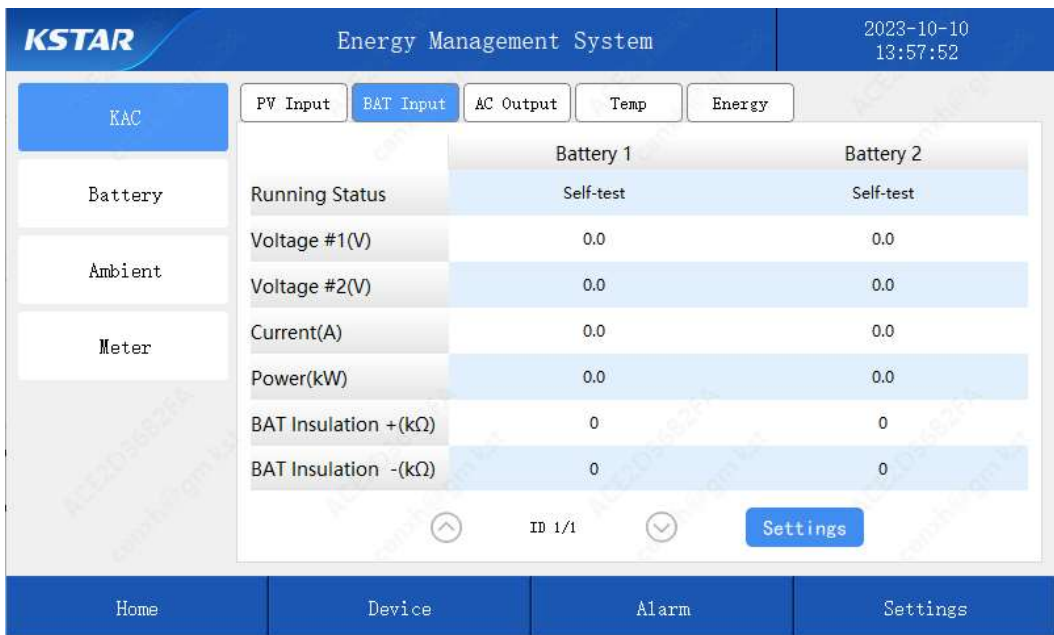

Fig. 9-5 Device-KAC -Battery Operation Information Page

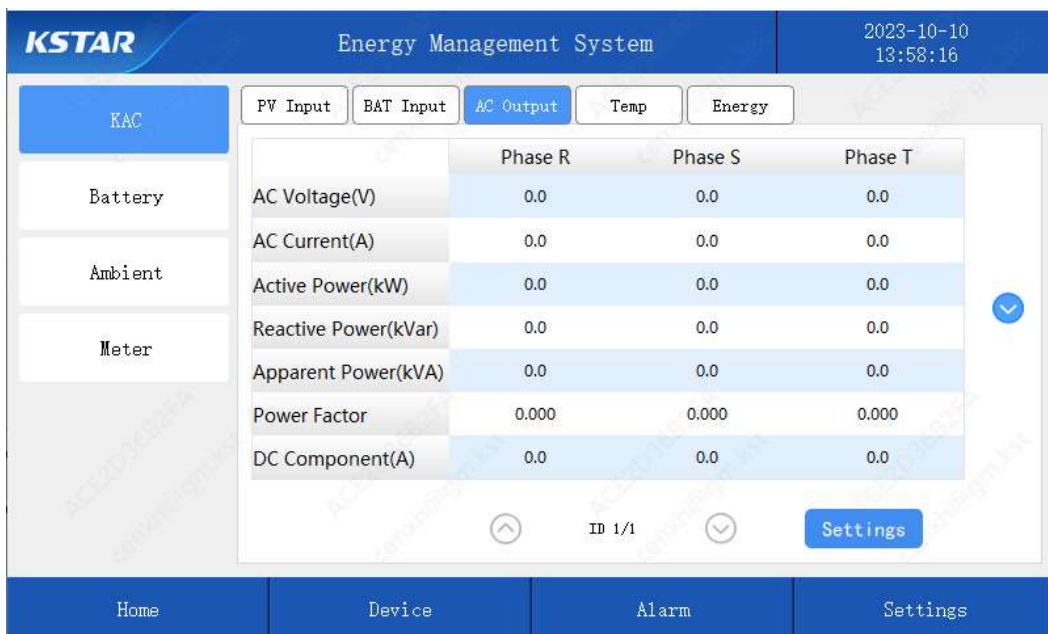

Fig. 9-6 Device-KAC-Converter Information Page

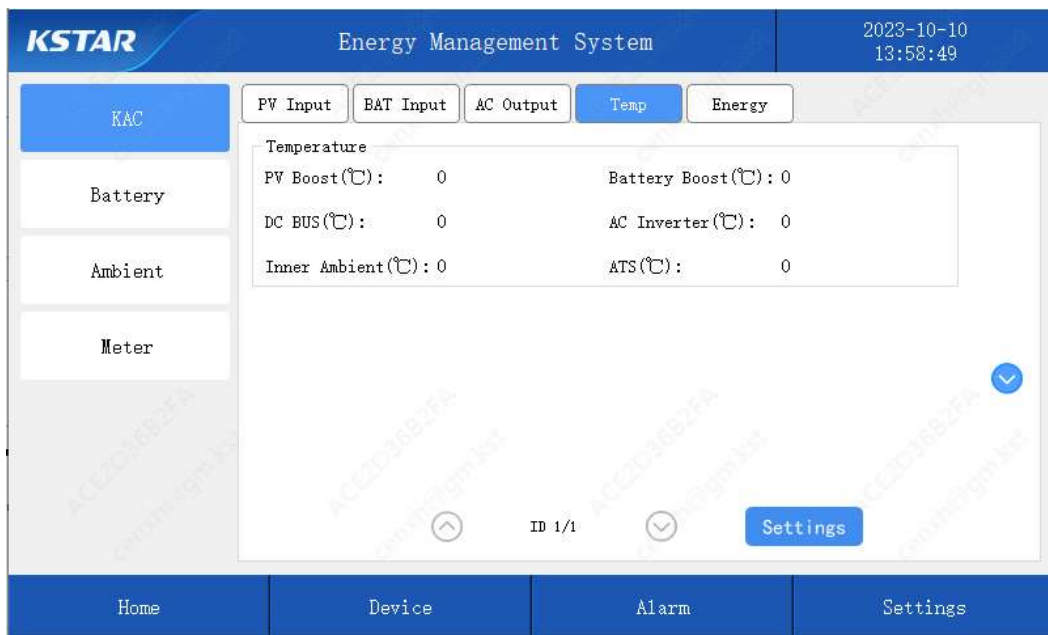

Fig. 9-7 Device-KAC-Temperature Information Page

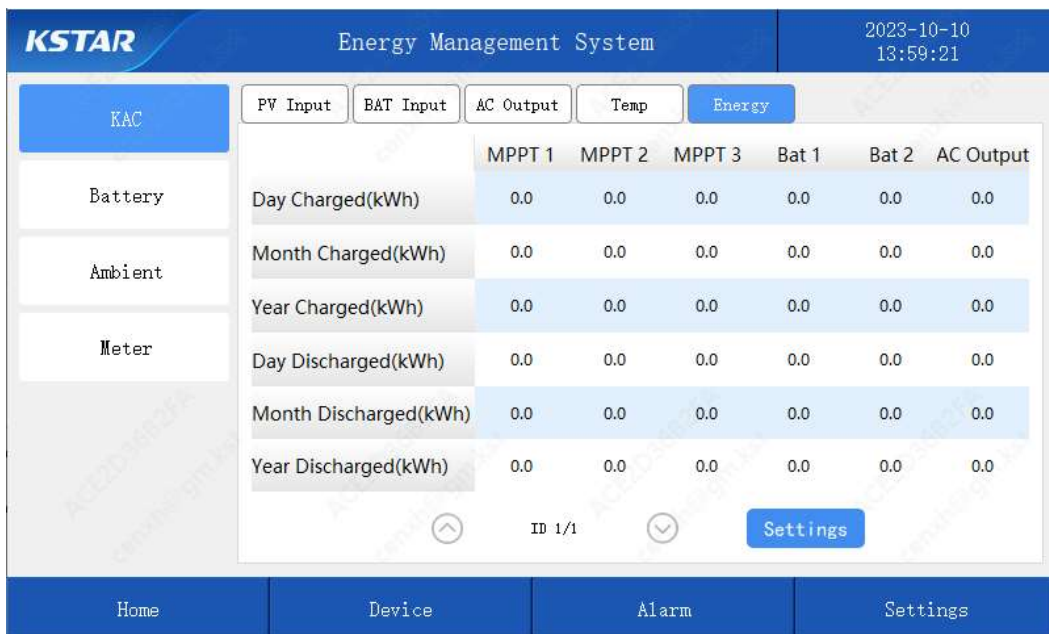

Fig. 9-8 Device-KAC-Charging and Discharging Capacity Statistics Information Page

Because KAC settings are related to system stability, it is not recommended that users change them. If the user needs to change the parameters, he needs to have certain professional knowledge and be fully familiar with the parameters of the local power grid system and the system before setting. At present, only general settings are open, and the manufacturer and maintenance settings are not open to users. If you have needs, you can consult KSTAR after-sales service to provide professional guidance.

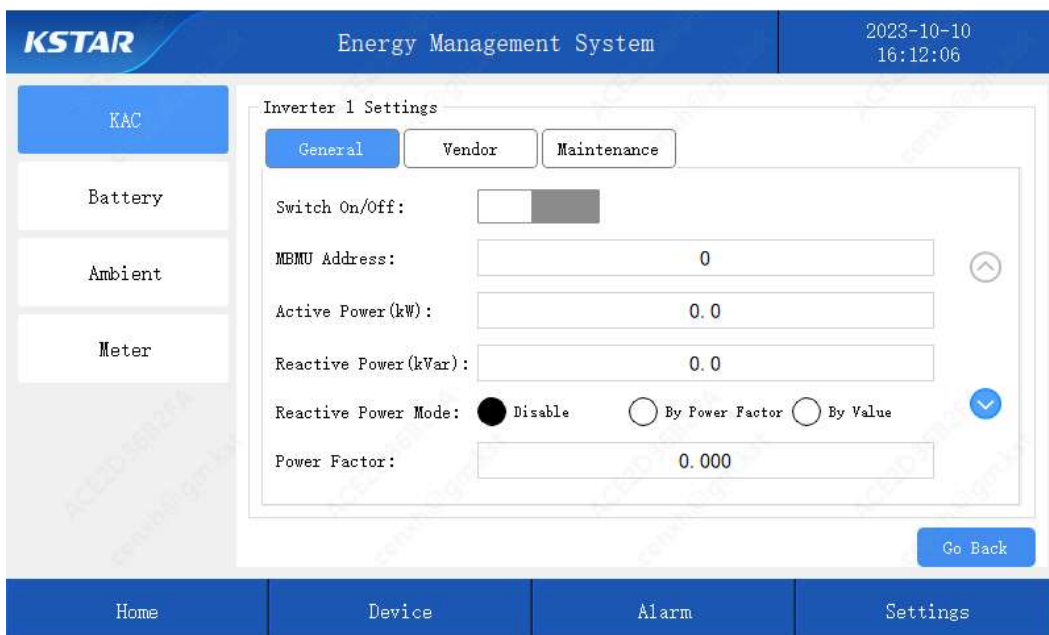

Fig. 9-9 Device-KAC-Settings Page 1

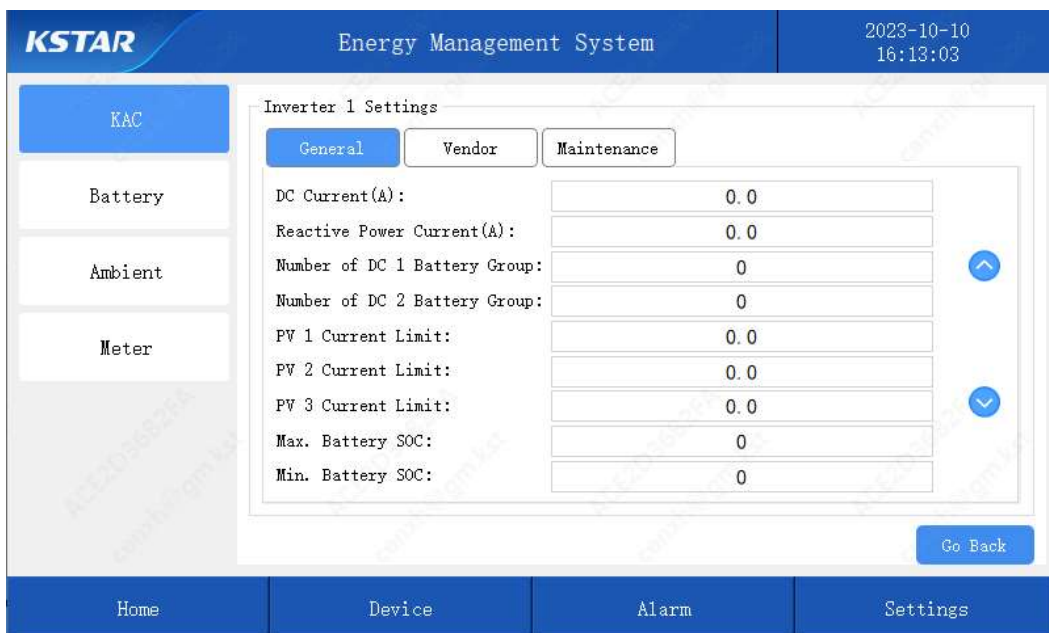

Fig. 9-10 Device-KAC-Settings Page 2

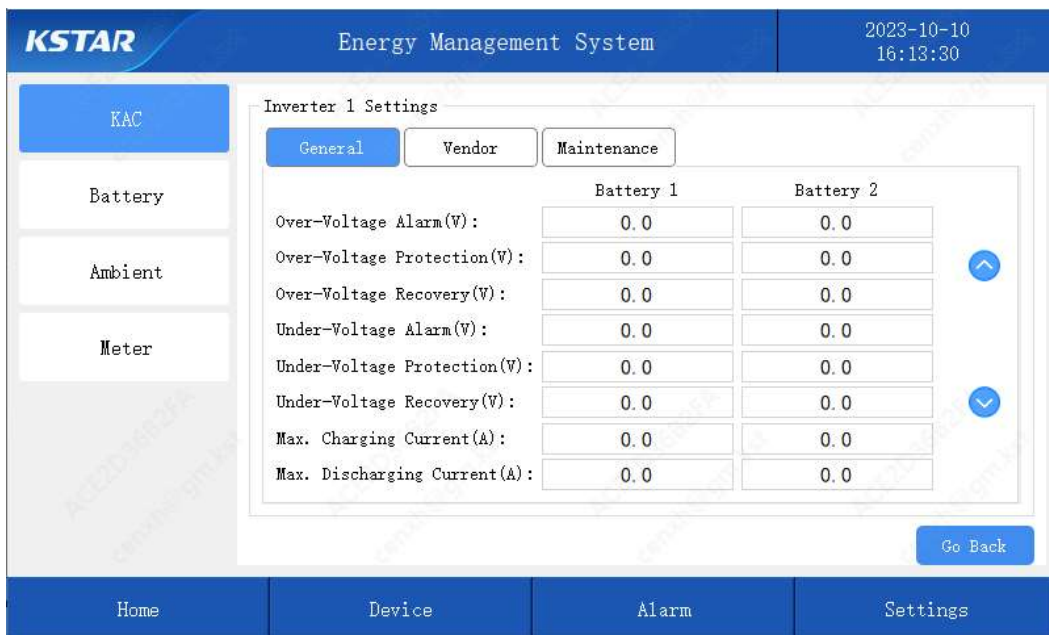

Fig. 9-11 Device-KAC-Settings Page 3

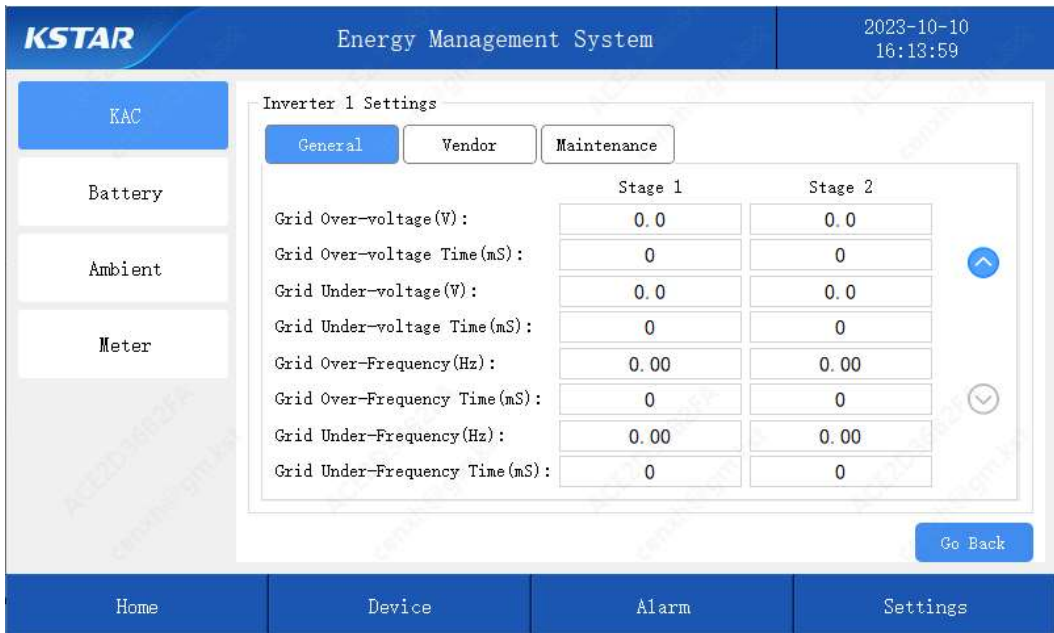

Fig. 9-12 Device-KAC-Settings Page 4

9.4.2 Device-Battery Page

On the Device-Battery page, you can view the information of battery branches and battery clusters. Battery branches refer to the link from the battery cluster to KAC-BAT1/BAT2, and each KAC corresponds to two branches. In single-machine and single-cabinet applications, the branch corresponds to the battery cluster; in single-machine and dual-cabinets applications, one branch corresponds to two battery clusters.

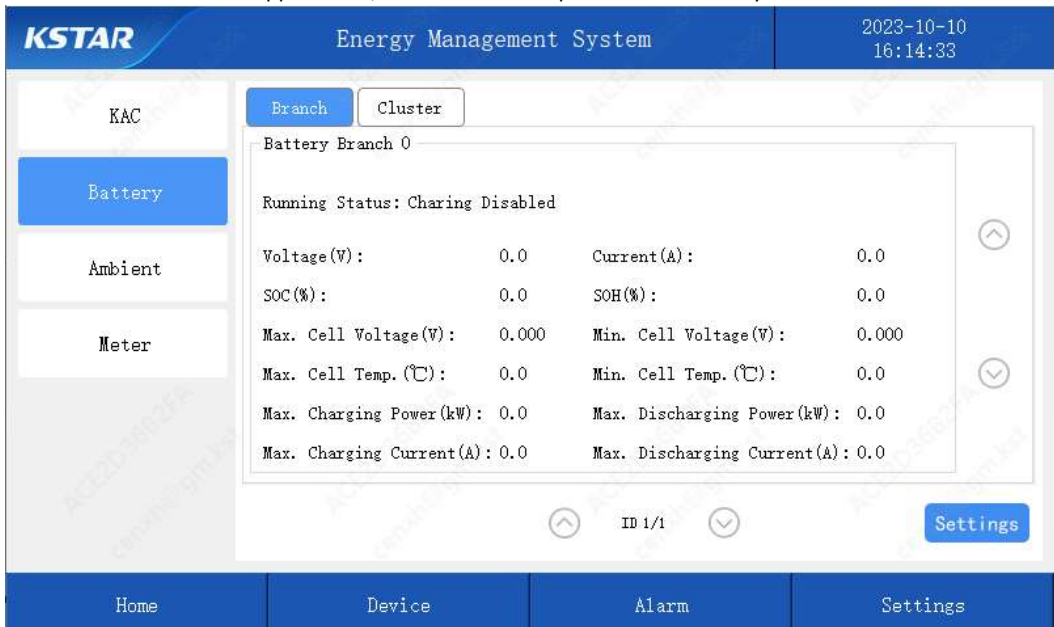

Fig. 9-13 Device-Battery-Battery Branch Information Page



Fig. 9-14 Device-Battery-Battery Cluster Information Page

On the Battery Settings page, you can set the IP address of the battery (default is 192.168.137.201:501), the upper charging limit of the battery SOC, and the lower discharging limit of the battery SOC. In the application of single-machine and dual-cabinet applications, you need to change the IP address of one of the cabinets to 192.168.137.20X:501, and the X setting range is 1-255, except for the default 201. The upper and lower limits of the battery SOC are set when enabled (Settings-Control-Battery SOC Control). This setting is effective during logical operation, and in the self-sufficient mode, setting the SOC upper limit to 100 will cause the system to stop running.

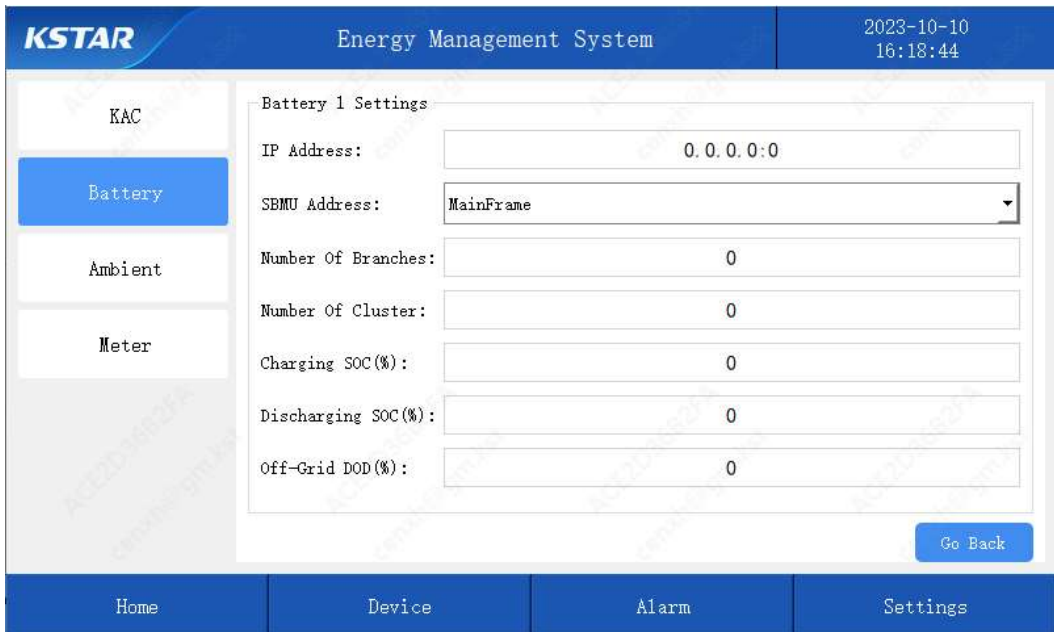

Fig. 9-15 Device-Battery-Battery Settings Page

9.4.3 Device-Ambient Page

On this page, you can view the battery cabinet temperature, waterlogging, fire alarm and other information. The green indicator indicates normal, and the red indicator indicates abnormal.

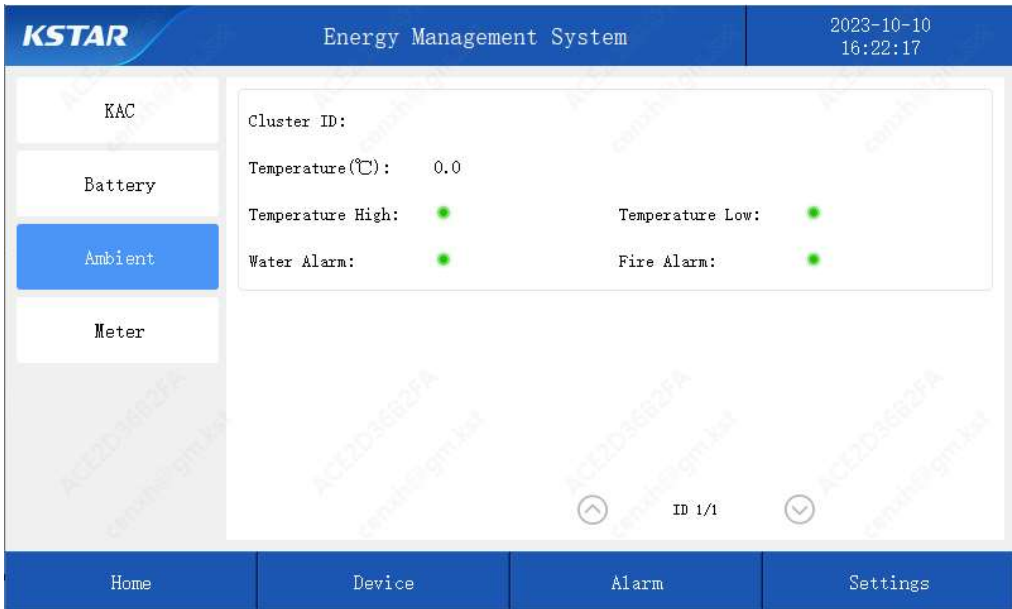

Fig. 9-16 Device-Ambient View Page

9.4.4 Device-Meter Page

On the Device-Meter page, you can view information such as voltage, current, and power uploaded to EMS by the Meter:



Fig. 9-17 Device-Meter Information View Page

9.5 Alarm Page

The alarm page can view the current system alarms, alarm logs, and system logs.

9.5.1 Alarm-Alarm Information Page

The alarm can view the alarm existing in the current system, the alarm occurrence time, the alarm device, and the alarm type.

Number: the number of alarm information detected by the current system;

Time: The time when the system detects the occurrence of the alarm;

Device: The device detected by the system that the alarm occurred;

Device ID: When the system is used in series and parallel for multiple devices, the alarm device is accurately located;

Information: Display the specific cause of the alarm for easy troubleshooting of the corresponding alarm.

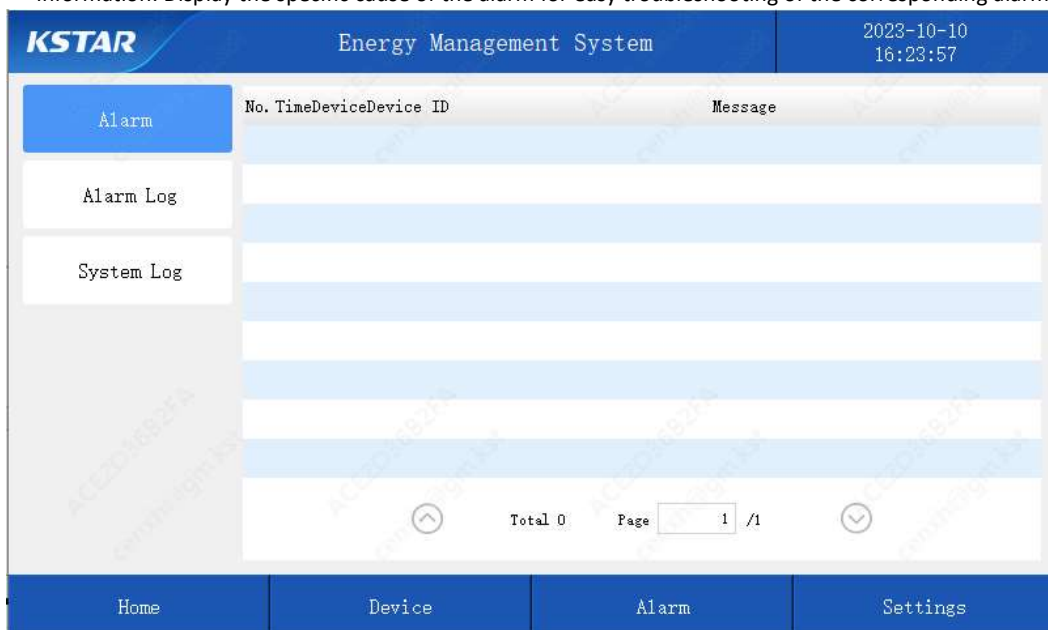

Fig. 9-18 Alarm-Alarm Page

9.5.2 Alarm-Alarm Log Page

The alarm log can view the historical information of system alarms.

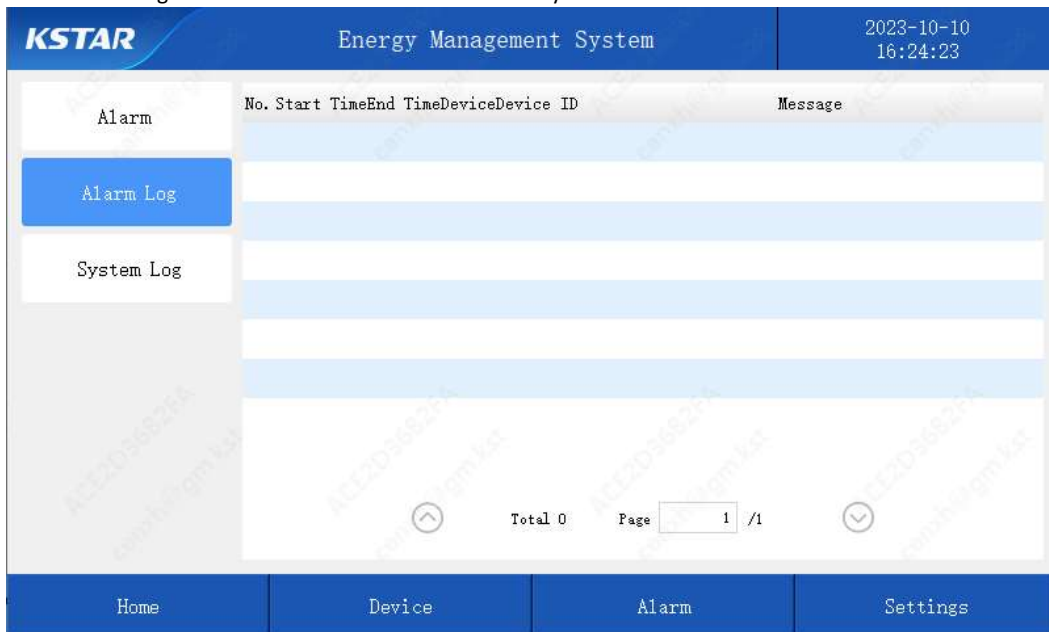

Fig. 9-19 Alarm-Alarm Log Page

9.5.3 Alarm-System Log Page

The system log can view system operation log information.

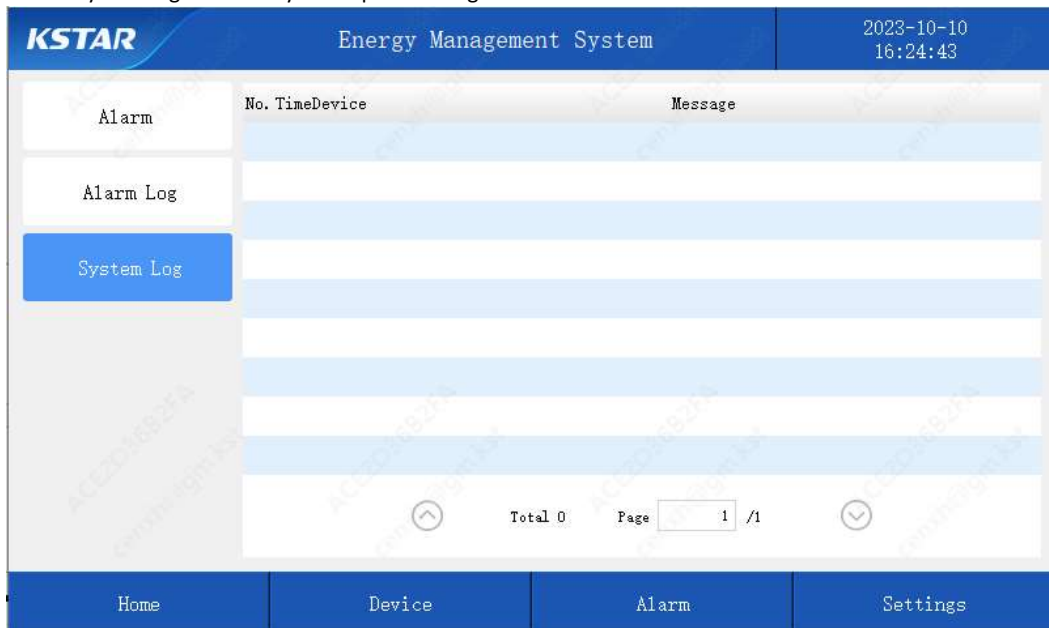

Fig. 9-20 Alarm-System Log Page

9.6 Settings Page

The settings include general settings, timesharing power settings, control settings, and language selection.

9.6.1 Settings-General Settings Page

On the Settings General Settings page, you can view the screen version, collector Serial Number, collector version, and time settings.

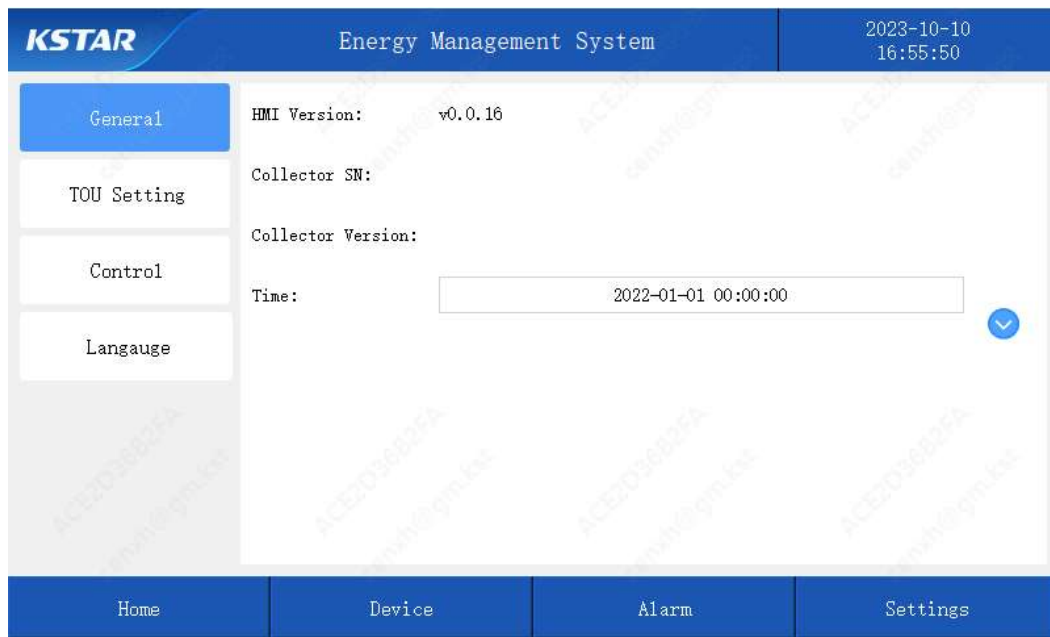

Fig. 9-21 Settings-General Settings 1 Page

On the General Settings page, click the button "⌵" to go to the next General Settings page, where you can choose a cloud server type. The cloud service platform needs to contact KSTAR after-sales engineer to activate, where: kems.ksdatacloud.com is the server type selected for domestic users; ems.ksdatacloud.com selects server types for foreign users; the type of power grid needs to be selected according to local power grid standards.

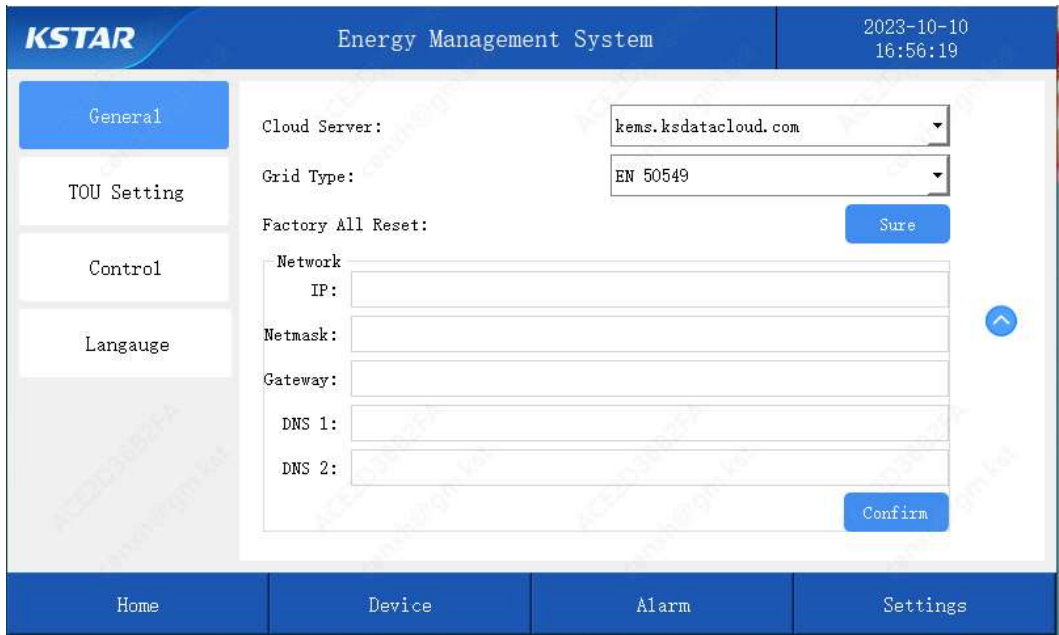

Fig. 9-22 Settings-General Settings Page

9.6.2 Settings-Timesharing Power Settings Page

On the Settings-Timesharing Power Settings page, you can set the running time and power value in the timesharing control mode on working days or weekends. The settings on this page are only valid when the running mode is timesharing. When setting the power value, a positive value represents charging, a negative value represents discharging, and this value is the power value on the AC side of the PCS. When there is a PV connection, if the system does not touch the upper and lower limits of SOC protection, does not touch the Anti-backflow control: or demand control, and there is no abnormal operation, the system will prioritize the PV MPPT operation to charge the battery. For example, on a sunny day, set the time period from 09:00 to 11:30 with a power of 50: when the PV power is 20KW, take another 30KW from the AC side to charge the battery; When the PV power is 45KW, the AC side power of the KAC is 5KW; When the PV is charged to the upper limit of SOC, the system will enter a hot standby state until the running power for another set time period.

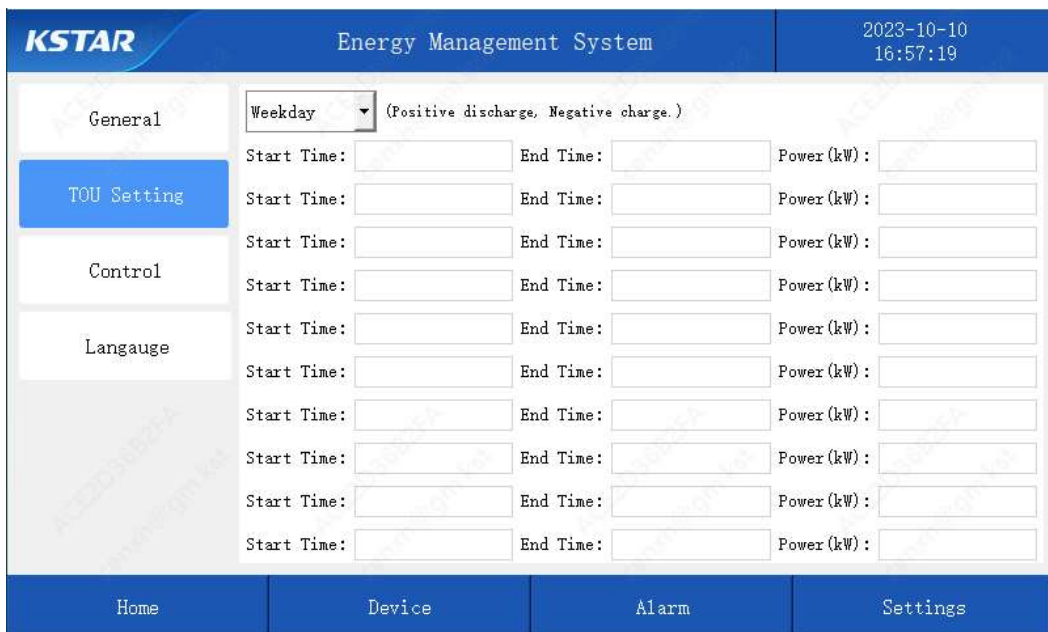

Fig. 9-23 Settings-Timesharing Power Settings Page

9.6.3 Settings-Control Settings Page

There are two buttons on the Settings-Control Settings page: Basic and Running mode. Below is an introduction to the options and their functions on the basic page:

4G Enable: After inserting a traffic card into EMS, enable 4G to upload system operation information to the cloud platform (cloud platform services can be activated by contacting KSTAR after-sales engineer after the system is power-on), facilitating users to remotely understand the system operation status.

Modbus TCP remote control: allows secondary EMS control, which is a reserved button and currently not applied.

Battery SOC control: When enabled, the system will operate within the set SOC range. The upper and lower limits of SOC charging and SOC discharge can be set in the "Device- Battery-Settings" section.

SOC return difference: set to prevent the system running status from switching back and forth when the battery is near the upper and lower limits of charging and discharging. For example, after enabling the SOC control of the battery, if the charging SOC of the battery is set to 98, the discharging SOC is set to 10, and the SOC return difference is set to 5, then the system will only allow the battery to charge again after the battery is charged to the upper limit of 98% and the discharging SOC is less than 93% (SOC upper limit - SOC return difference). Similarly, after the system discharges to the lower limit of 10%, the battery is only allowed to discharge again when the SOC exceeds 15% (SOC lower limit+SOC return difference).

Local Modbus TCP address: distinguishes the ID address of the first level EMS, which is a reserved button and is not currently applied.

KAC Number: Set the KAC Number controlled by this system, with both single and dual cabinets set to 1.

BMS Number: Set the BMS Number (battery cabinets) controlled by this system to 1 for a single-machine and 2 for a single-machine and dual-cabinets.

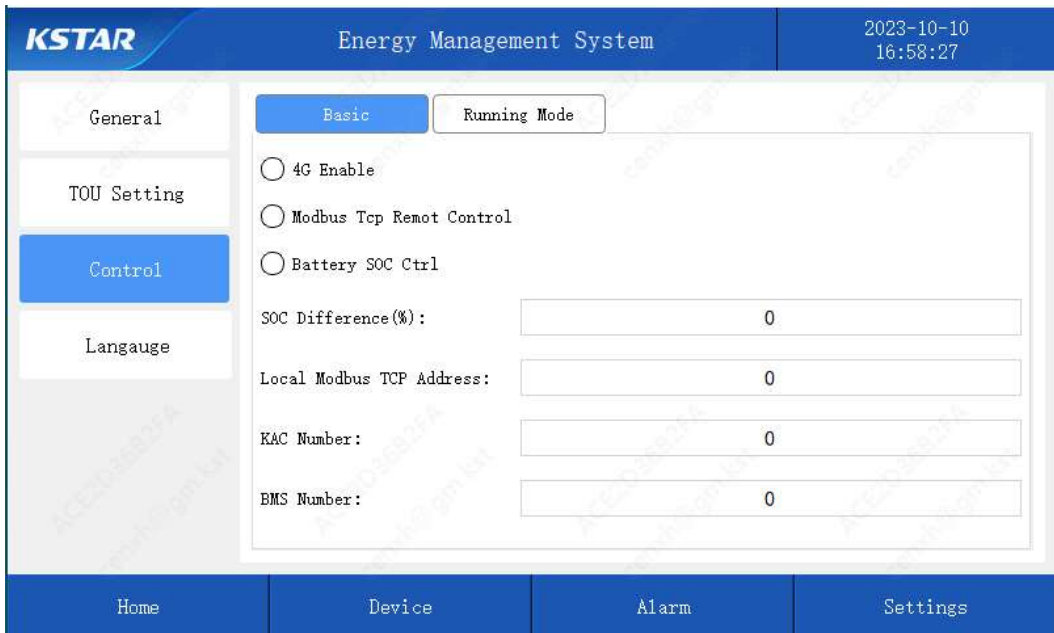

Fig. 9-24 Settings-Basic Settings Page

On the Settings-Control-Running Mode page, you can select manual control, self-sufficient, timesharing control, peak load shifting and battery backup mode.

1. Manual control: As shown in the figure below, in the manual control mode, the KAC can be controlled on and off and the running power.

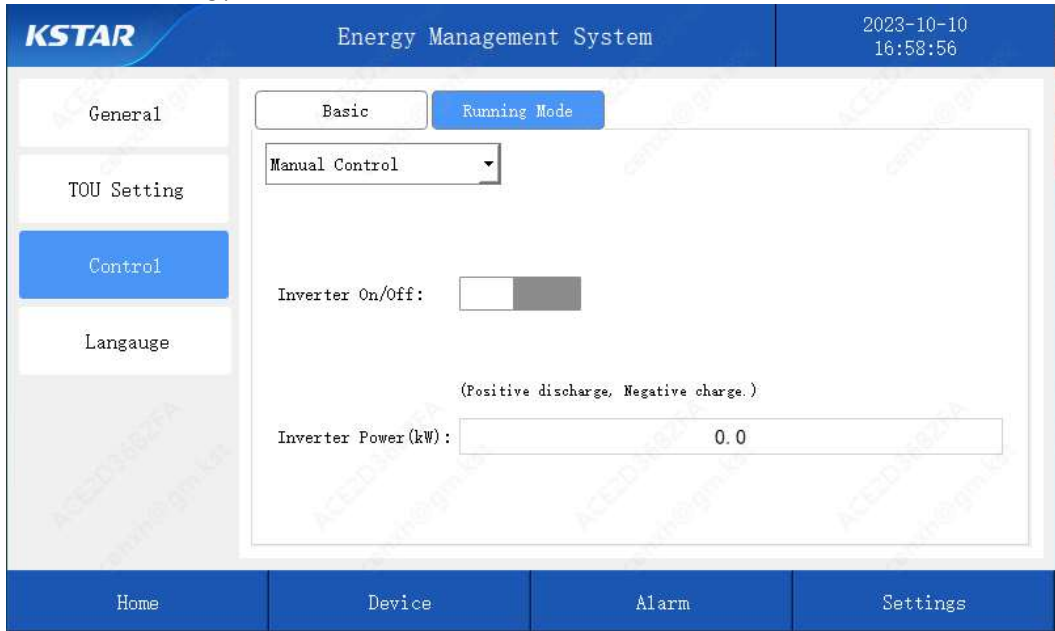

Fig. 9-26 Settings-Running Mode-Manual Control Settings Page

2. Self-sufficient mode: This mode is suitable for users who use PV or other power generation devices together. There are four settings in the self-sufficient mode that users need to set based on actual operation conditions.

Charging time: Enable this setting, the system charges the battery according to the set power (when the demand control is not triggered) during the set time period. If the PV+ charging power is greater than the allowable charging power of the battery during this time period, the system prioritizes PV charging and automatically reduces the charging power on the AC side to maximize revenue.

Anti-backflow control:: After enabling this setting, when the system reads that the power feed to the grid sampled by the meter is less than the set value, the system continues to increase the discharge power, supply power to the load and feed to the grid, and maintain the feed power in the set value attachment until the full power output of the system. The user needs to set this value according to the application scenario; when this setting is not enabled, the PV preferentially supplies power to the load, and the remaining energy charges the battery.

Demand control: Demand control works during the system charging period. When this setting is enabled, the system will automatically control the system AC side charging power according to the setting value. When the system detects that the meter reading is less than the set value, the system charges according to the power set by the set charging period; When the system detects that the meter reading is greater than the set value, the system will automatically reduce the power charged from the AC side, maintain the meter near the demand control value, and prevent the LAN from tripping, powering off or damaging due to overload. The user needs to set this value according to the scenario.

AC coupling: This setting is an option when other power generation equipment is coupled on the AC side of the system, that is, the PCS and other power generation equipment share the AC bus. After this option is enabled, if the anti-back current value is enabled, when the meter samples the feeder power less than the anti-back current value, the KAC sends the electrical power down, so that the feeder power is maintained near the set anti-back current value until the KAC is discharged at full power; If the anti-back current value is not enabled, when the meter samples the power flowing to the grid, the system issues a charging command to absorb the power

generated by the power generation equipment until the KAC is charged at full power and limits the PV power in the system.

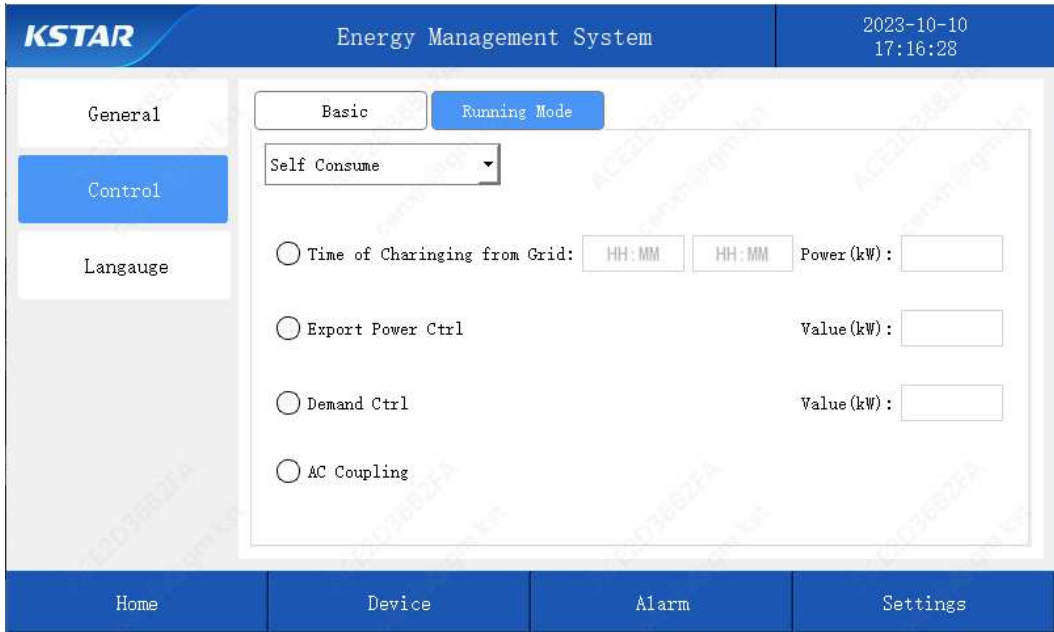

Fig. 9-27 Settings-Running Mode-Self-sufficient Settings Page

3. Timesharing control mode: After selecting this mode, the system operates according to the set timesharing power. Anti-backflow control and demand control refer to the Self-sufficient mode set according to actual running conditions.

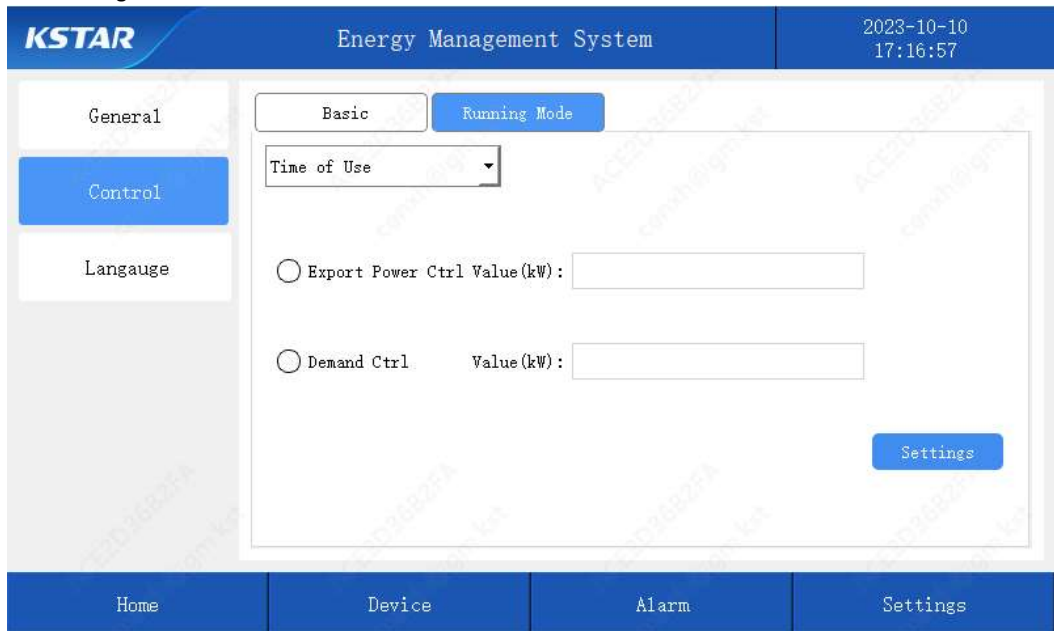

Fig. 9-28 Settings-Running Mode-Timesharing Control Settings Page

4. Peak load shifting mode: After selecting this mode, enable the valley power, when the meter reading is less than the valley power, if the current SOC of the system is less than the upper limit of the battery SOC, a

charging command will be issued to maintain the meter reading in the valley power accessory or reach the max charging power of the system. Enable the peak power, when the meter reading is greater than the peak power, if the current SOC of the system is greater than the lower limit of the battery SOC, a power command will be issued to maintain the meter reading in the peak power accessory until the max discharge power of the system is reached.

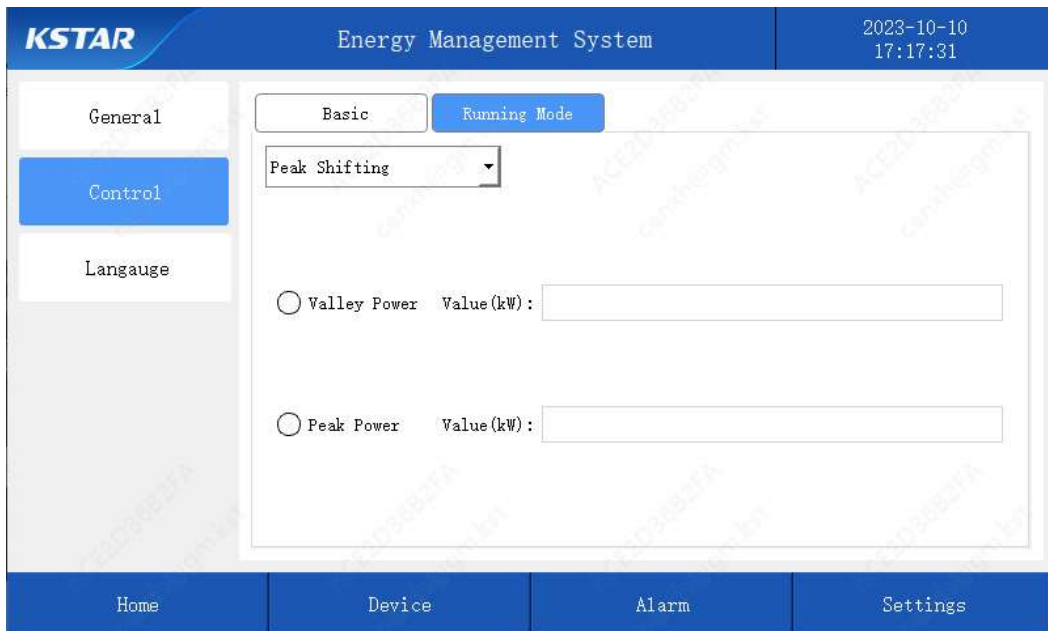

Fig. 9-29 Settings-Running Mode-Peak Load Shifting Settings Page

5. Battery backup mode: After selecting this mode, the user needs to set the required power backup. Enable demand control, and the system will automatically adjust the rechargeable power according to the meter reading, preventing the local power grid from tripping due to overload. When the meter reading is less than the demand control value, the system will charge the battery at full power; when the meter reading is greater than the demand control value, the system reduces the battery charging power to keep the meter near the demand control value.

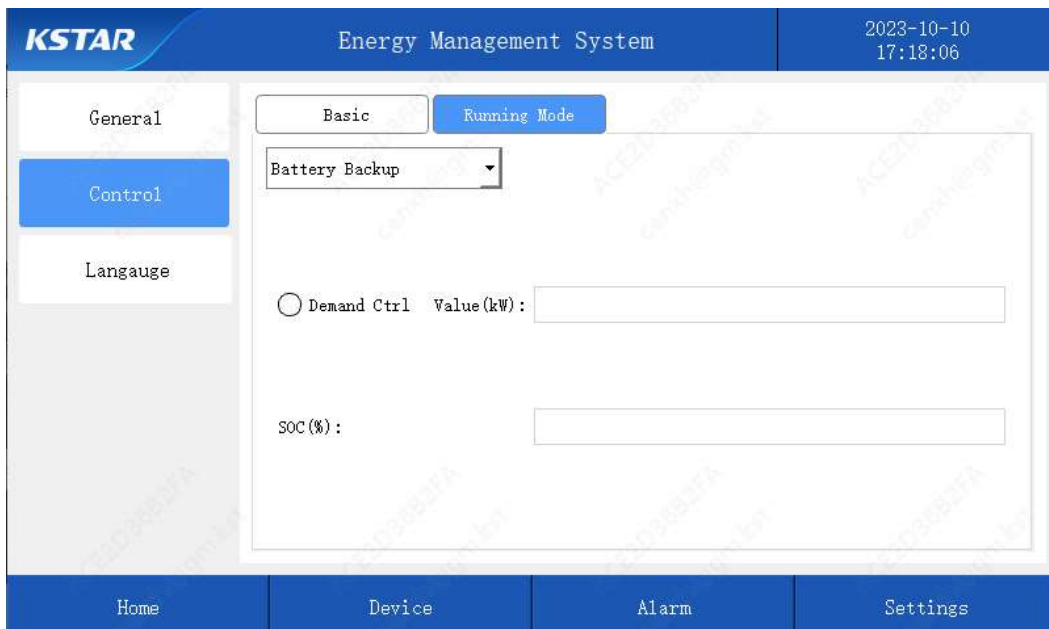

Fig. 9-29 Settings-Running Mode-Battery Backup Settings Page

9.6.4 Settings-Language Settings Page

The language settings page can choose the language method for screen usage, and currently only supports switching between Chinese and English.



Fig. 9-30 Settings-Language Settings Page

10 Troubleshooting

10.1 Node Failure Information & Troubleshooting Methods

Battery failure: The level 1 alarm is only a system pre-warning information; the level 2 alarm is a general alarm, and the system stops running; Level 3 and 4 alarms are serious alarms, not allowed to boot, need to contact KSTAR after-sales engineers to deal with it.

Type	Level	Cause	Solution
Pre-charging timed out	The battery is not working	The external load is too large, which affects the pre-charging process	Restart the system
Single battery voltage is too high	Level 1 alarm	Abnormal charging, abnormal communication with PCS	Discharge or check the communication line
	Level 2 alarm	Abnormal charging, abnormal communication with PCS	Discharge or check the communication line
	Level 3 alarm	Abnormal charging, abnormal communication with PCS	Discharge or check the communication line
	Level 4 alarm	Abnormal charging, abnormal communication with PCS	Contact KSTAR personnel
Single battery voltage is too low	Level 1 alarm	Abnormal discharge, abnormal communication with PCS	Charge or check the communication line
	Level 2 alarm	Abnormal discharge, abnormal communication with PCS	Charge or check the communication line
	Level 3 alarm	Abnormal discharge, abnormal communication with PCS	Charge or check the communication line
	Level 4 alarm	Abnormal discharge, abnormal communication with PCS	Contact KSTAR personnel
Total voltage too high	Level 1 alarm	Abnormal charging, abnormal communication with PCS	Discharge or check the communication line
	Level 2 alarm	Abnormal charging, abnormal communication with PCS	Discharge or check the communication line
	Level 3 alarm	Abnormal charging, abnormal communication with PCS	Discharge or check the communication line
	Level 4 alarm	Abnormal charging, abnormal communication with PCS	Contact KSTAR personnel
Total voltage too low	Level 1 alarm	Abnormal discharge, abnormal communication with PCS	Charge or check the communication line
	Level 2 alarm	Abnormal discharge, abnormal communication with PCS	Charge or check the communication line
	Level 3 alarm	Abnormal discharge, abnormal communication with PCS	Charge or check the communication line
	Level 4 alarm	Abnormal discharge, abnormal communication with PCS	Contact KSTAR personnel
Battery discharge temperature too high	Level 1 alarm	Air conditioner abnormal, working environment temperature too high	Cool down, clean the air conditioner

	Level 2 alarm	Air conditioner abnormal, working environment temperature too high	Cool down, clean the air conditioner
	Level 3 alarm	Air conditioner abnormal, working environment temperature too high	Cool down, clean the air conditioner
Battery discharge temperature too high	Level 4 alarm	The working environment temperature is too high, or the battery is seriously aging, and there is a risk of thermal runaway	Contact KSTAR personnel
Battery discharge temperature too high	Level 1 alarm	Air conditioner abnormal, working environment temperature too high	Cool down, clean the air conditioner
	Level 2 alarm	Air conditioner abnormal, working environment temperature too high	Cool down, clean the air conditioner
	Level 3 alarm	Air conditioner abnormal, working environment temperature too high	Cool down, clean the air conditioner
	Level 4 alarm	The working environment temperature is too high, or the battery is seriously aging, and there is a risk of thermal runaway	Contact KSTAR personnel
Battery charge temperature too low	Level 1 alarm	Air conditioner abnormal, working environment temperature too low	Increase temperature, clean the air conditioner
	Level 2 alarm	Air conditioner abnormal, working environment temperature too low	Increase temperature, clean the air conditioner
	Level 3 alarm	Air conditioner abnormal, working environment temperature too low	Increase temperature, clean the air conditioner
Battery discharge temperature too low	Level 1 alarm	Air conditioner abnormal, working environment temperature too low	Increase temperature, clean the air conditioner
	Level 2 alarm	Air conditioner abnormal, working environment temperature too low	Increase temperature, clean the air conditioner
	Level 3 alarm	Air conditioner abnormal, working environment temperature too low	Increase temperature, clean the air conditioner
Single cell temperature difference too large	Level 1 alarm	Abnormal air-conditioning duct, abnormal sampling	Clean the air conditioner or contact KSTAR personnel
Charging current too high	Level 1 alarm	Abnormal charging, abnormal communication with PCS	Check the communication line and PCS
	Level 2 alarm	Abnormal charging, abnormal communication with PCS	Check the communication line and PCS

	Level 3 alarm	Abnormal charging, abnormal communication with PCS	Check the communication line and PCS
Discharge current too high	Level 1 alarm	Abnormal discharge, abnormal communication with PCS	Check the communication line and PCS
	Level 2 alarm	Abnormal discharge, abnormal communication with PCS	Check the communication line and PCS
	Level 3 alarm	Abnormal discharge, abnormal communication with PCS	Check the communication line and PCS
Insulation fault	Level 1 alarm	Battery cabinet soaked in water, poor earthing	Check the earthing of the battery cabinet and whether there is water mist in the cabinet
	Level 2 alarm	Battery cabinet soaked in water, poor earthing	Check the earthing of the battery cabinet and whether there is water mist in the cabinet
	Level 3 alarm	Battery cabinet soaked in water, poor earthing	Check the earthing of the battery cabinet and whether there is water mist in the cabinet
PCS communication failure	Level 2 alarm	Abnormal communication with PCS	Check the communication line and PCS
Internal communication failure	Level 2 alarm	Abnormal wiring in the cabinet	Check the wiring between the high voltage box and the battery module in the cabinet
Main positive relay failure	Level 4 alarm	Relay abnormal	Contact KSTAR personnel
Main negative relay failure	Level 4 alarm	Relay abnormal	Contact KSTAR personnel
Cell voltage failure	Level 2 alarm	Abnormal sampling line	Check the connection of the sampling line of the battery module
Cell temperature failure	Level 2 alarm	Battery module sampling line abnormal	Check the connection of the battery module sampling line
AFE chip failure	Level 3 alarm	Battery module sampling board abnormal	Contact KSTAR personnel
Equalization circuit failure	Level 3 alarm	Battery module sampling board abnormal	Contact KSTAR personnel
Current sensor failure	Level 3 alarm	Sampling failure in the high-voltage box	Contact KSTAR personnel
Battery system failure	Level 3 alarm	High voltage box failure	Contact KSTAR personnel
Abnormal high voltage fault	Level 2 alarm	Connection between the battery module and the high voltage box is abnormal	Check the connection of the power line between the high voltage box and the battery module
Pole temperature too high	Level 1 alarm	Abnormal charge/discharge, abnormal communication with PCS	Stop charging/discharging, cool down
	Level 2 alarm	Abnormal charge/discharge, abnormal communication with PCS	Stop charging/discharging, cool down

	Level 3 alarm	Abnormal charge/discharge, abnormal communication with PCS	Stop charging/discharging, cool down
Ambient temperature failure	Level 1 alarm	Sampling failure in high procure box	Contact KSTAR personnel
Ambient temperature too high	Level 1 alarm	Ambient temperature of the battery cabinet is too high	Adjust the location of the battery cabinet
Ambient temperature too low	Level 1 alarm	Ambient temperature of the battery cabinet is too low	Adjust the location of the battery cabinet
Fire fault	Level 4 alarm	Battery thermal runaway	Contact KSTAR personnel
Flooding fault	Level 4 alarm	Battery cabinet is flooded	Contact KSTAR personnel
Access control alarm	Level 2 alarm	Door of the battery cabinet is not locked	Check the door and lock it
Total voltage difference fault	Level 2 alarm	Connection between the battery module and the high voltage box is abnormal	Check the power line connection between the high voltage box and the battery module
B+ pole temperature fault	Level 1 alarm	Sampling failure in the high voltage box	Contact KSTAR personnel
B- pole temperature fault	Level 1 alarm	Sampling failure in the high voltage box	Contact KSTAR personnel
SPD lightning arrester failure	Level 3 alarm	Lightning strike inspection	Change the placement and replace the lightning arrester
Meter communication failure	Level 2 alarm	Abnormal communication with the meter	Check the communication line and Meter

Table 10-1 Common Battery Failure and Solution

PCS failure:

Type	Solution
Low battery voltage	Disconnect the DC switch and check the DC side voltage and the configuration of the energy storage battery
High battery voltage	Disconnect the DC switch and check the DC side voltage and the configuration of the energy storage battery
Battery reverse connection fault	Disconnect the DC switch and check the positive and negative wiring of the energy storage battery
Battery hardware overcurrent	Shut down and check whether the input and output of the converter are overloaded or short-circuited
PV reverse connection fault	Disconnect the switch on the PV side and check the positive and negative wiring on the PV side
PV voltage too high	Disconnect the switch on the PV side and check the PV side voltage configuration
PV hardware overcurrent	Shut down, check whether the PV side input is overloaded or short-circuited
Grid voltage too high	Shut down, check the on-grid point voltage

Grid voltage too low	Shut down, check the on-grid point voltage
Grid voltage reversed	Disconnect the grid power transmission switch, and shut down to check the three-phase wiring
Grid frequency abnormal	Shut down and check grid voltage
Output relay fault	Shut down, check whether the AC relay is damaged
Converter overcurrent	Shut down, check whether the input and output of the converter are short-circuited or whether the converter is overloaded
Cycle-by-cycle current limit of converter	Shut down, check whether the input and output of the converter are short-circuited or whether the converter is overloaded
Converter over-temperature	Shut down, check whether the fan of the converter is faulty and whether the air duct is unobstructed
Converter out of sync	Shut down, check the converter settings, and check whether the parallel cables are properly connected
Lightning protection failure	Shut down, check the lightning protection of the converter
BMS communication fault	Shut down, check whether the communication cable between the converter and the battery system is loose
EPO failure	Shut down, check if the EPO button is pressed

Table 10-2 Converter Failure and Solution

10.2 Alarm Positioning and Troubleshooting

On the Alarm page, you can view the current alarm occurrence time, alarm device, and reason of the alarm, and troubleshoot the problem according to the corresponding alarm information.

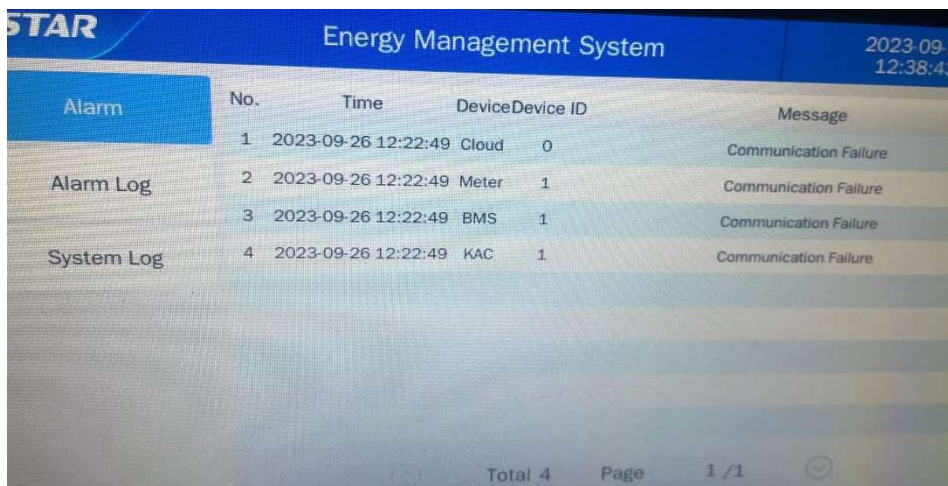

Fig. 10-1 Alarm View and Troubleshooting

11 Firefighting Instructions

11.1 General

Observe the fire codes and regulations of the country where the project is located.

Regularly inspect and maintain fire-fighting equipment to ensure that all functional indicators are normal.

11.2 Firefighting System Introduction

1. Cabinet Firefighting System: It is composed of smoke detection device, firefighting thermal line, fire starter box and firefighting aerosol.

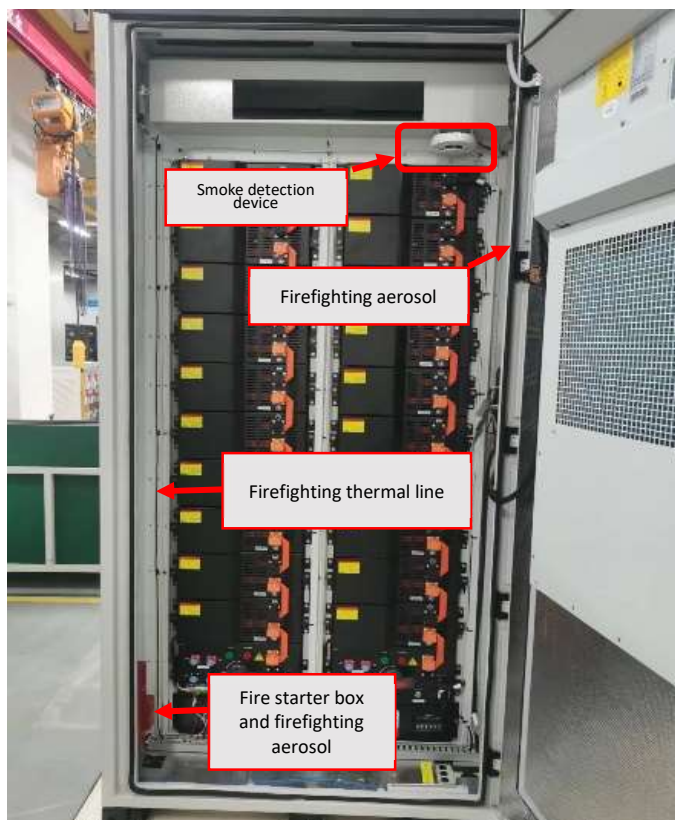

Smoke triggering: When the smoke detection device detects smoke in the battery cabinet, the device will sound an alarm and upload the signal to the J10-D15 port of the EMS by changing the internal dry contact status. After the EMS receives the smoke signal, the system operation is stopped, the battery high-voltage circuit breaker is disconnected, and the AC auxiliary switch in the battery cabinet jumps open.

Thermal triggering: When the thermal line detects a fire signal, the thermal line transmits the fire signal to the trigger circuit through the booster circuit and the electric initiator, and starts the combined fixed aerosol fire extinguishing device. After the fire trigger, through the dry contact point connected to the DI4 dry contact of SBMU, DI4 pull up (H) indicates the fire trigger signal, SBMU detects the fire trigger signal, for 2 seconds, SBMU reports fire failure, locks the battery pack, trips, immediately disconnects the relay, and the system stops working. Fire faults need to be cleared manually.

2. Pack Firefighting: It is packaged in the battery module and placed on top of the Pack, integrating automatic fire detection and firefighting functions. When the thermal line detects the fire source signal (about 180°C), the thermal line is immediately activated and conducted to the firefighting device (hot aerosol) to start the full cover firefighting.

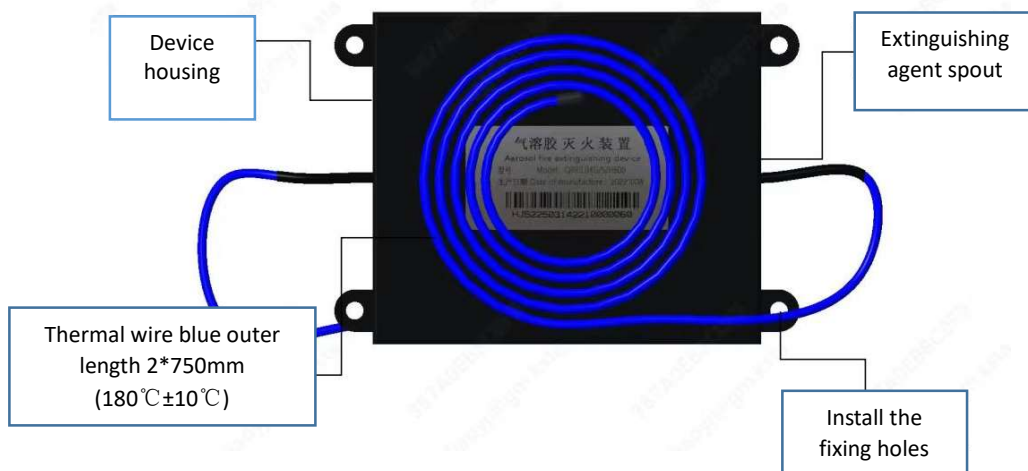

The system adopts a new type of firefighting device, the temperature sensing material is made of special molecular material, and the clean extinguishing agent is installed inside the fire extinguishing module. When the surface of the temperature-sensitive material is heated, a trigger signal will be formed to release the extinguishing agent from the nozzle of the firefighting device, thereby suppressing the fire.

ATTENTION

Choking hazard! A large amount of gas will be generated when the equipment automatically extinguishes the fire. Do not approach the outdoor battery cabinet during firefighting.

12 Daily Operation and Maintenance

12.1 Safety Precautions

WARNING

There is a deadly high voltage inside the cabinet equipment of the integrated ESS, and there is a risk of fatal electric shock if accidentally touched.

After shutting down, please wait at least 10 minutes before opening the cabinet door. Before carrying out maintenance work, make sure that the inside of the equipment is completely de-energized.

WARNING

Only qualified and authorized personnel can perform maintenance and other operations on the integrated ESS.

When performing maintenance work, do not leave screws, washers and other metal parts in the integrated ESS, or the equipment may be damaged!

WARNING

The entry of wind, sand and moisture may damage the electrical equipment in the integrated ESS, or affect the performance of the equipment!

- During the sandstorm season, or when the relative humidity in the surrounding environment is greater than 95%, do not open the door of the equipment cabinet in the integrated ESS.
- Maintenance work can only be started when there is no sandstorm and the weather is sunny and dry.

WARNING

If only the AC and DC switches are disconnected, the cable connection terminals inside the AC and DC cabinet of the integrated ESS are still charged! To avoid the risk of electric shock, before maintenance and inspection:

- Disconnect all AC and DC side switches;
- Disconnect the front and rear circuit breakers of the integrated ESS.

12.2 Maintenance Introduction

12.2.1 Overview

The integrated ESS has IP54 protection level and is suitable for outdoor use. However, the harsh environment or long-term operation will still cause the aging of the integrated ESS or the damage of internal equipment. Regular maintenance and inspection of the integrated ESS, replacement of aging and damaged parts will effectively prolong its service life and improve the performance of internal equipment.

Occasional checks are necessary, especially when the overall system performance is poor.

12.2.2 Maintenance Cycle

Regular maintenance is required in order to ensure the good operation of the equipment in the outdoor battery cabinet and the PCS.

The maintenance intervals given in this section are reference values. The actual maintenance cycle should be reasonably determined in combination with the actual environmental conditions of the project site. If the running environment of the outdoor battery cabinet and the PCS is relatively harsh, such as a desert area, the corresponding maintenance cycle should be shortened.

Especially internal and external cleaning, anti-corrosion and anti-rust work, should be more frequent. If the system is installed in a desert area, it is recommended that the inside and outside of the outdoor battery cabinet and PCS should be carefully inspected and cleaned thoroughly after each sandstorm.

 **WARNING**

It is necessary to regularly check whether the cooling blowers and fans of the outdoor battery cabinet and PCS are running normally, and observe whether there is friction sound during operation. If yes, it may be caused by dust entry, and the outdoor battery cabinet and PCS need to be stopped before clearing the dust.

After the outdoor battery cabinet and PCS are completely powered off, wait at least 10 minutes for the internal capacitors to discharge completely. Before clearing the dust, please use a multimeter to confirm that the inside of the machine is completely de-energized to avoid electric shock.

 **WARNING**

Most of the maintenance work needs to remove the protective cover inside the machine before it can be carried out. After all maintenance work is over, be sure to restore all removed maintenance covers to their original state.
Make sure all screws are tight in place.

 **WARNING**

When performing routine maintenance, inspection and other work on the internal equipment of the outdoor battery cabinet, once any non-conformity is found, please correct it immediately. If in doubt, please contact KSTAR immediately.

Check the following items and correct them immediately if they do not meet the requirements:

<p>Safety function (every three months)</p> <ul style="list-style-type: none">◆ Check the emergency stop button and HMI stop function.◆ Check the warning signs and other equipment markings on the body. If you find blurry or damaged, please replace them in time.◆ Fire starter box: Press the red button on the starter box, and the power indicator light (left side) and return light indicator light (right side) of the device are always on.◆ Simulated smoke alarm: Spraying a certain concentration of smoke at the smoke detection device triggers the system to shut down. If there is any abnormality, please contact KSTAR after-sales personnel for maintenance in time.
<p>Inside the system (every month)</p> <ul style="list-style-type: none">◆ After the battery outdoor cabinet and the internal equipment of the PCS are completely powered off, then start the checking! During the checking, if there is any abnormality, it needs to be corrected immediately.◆ Check whether the outdoor battery cabinet, PCS and internal equipment are damaged or deformed.◆ Check whether the system alarms and logs for any abnormalities.◆ Check whether there is any abnormal noise during the operation of the internal equipment.◆ Check whether the temperature inside the outdoor battery cabinet and the PCS is too high.◆ Check whether the internal humidity and gray scale of the outdoor battery cabinet and PCS are within the normal range. Clean if necessary.◆ Check whether the air inlet and outlet of the outdoor battery cabinet and PCS are blocked.◆ Check the following items, and correct them immediately if they do not meet the requirements:◆ Check whether there are flammable objects on the top of the outdoor battery cabinet and the PCS.◆ Check whether there is water leakage inside the outdoor battery cabinet and PCS.
<p>Cabinet exterior (every six months)</p> <ul style="list-style-type: none">◆ Check whether there are foreign objects, dust, dirt and condensed water inside the battery outdoor cabinet and PCS.◆ Check whether the cable layout is standardized and whether there is a short circuit. If there is any abnormality, it needs to be corrected immediately.◆ Check whether all the inlet and outlet holes of the outdoor battery cabinet and the PCS are well sealed.◆ Check whether the welding points between the outdoor battery cabinet and the foundation steel plate are firm and whether there is corrosion.

<p>Wiring (every six months)</p> <ul style="list-style-type: none">◆ Check whether the power cable connection is loose, and retighten it according to the previously specified torque.◆ Check whether the power cables and control cables are damaged, especially whether there are cut marks on the skin in contact with the metal surface.◆ Check whether the insulation binding tape of the power cable terminal is peeled off.
<p>Grounding and equipotential bonding (every six months)</p> <ul style="list-style-type: none">◆ Check whether the earthing connection is correct, and the earth resistance should not exceed 4Ω.◆ Check whether the equipotential connection inside the outdoor battery cabinet and the PCS is correct.
<p>Air conditioning and fan (every six months)</p> <ul style="list-style-type: none">◆ Check the running status of the air conditioning and fan.◆ Check whether the air conditioning drainage hole is blocked.◆ Check whether there is abnormal noise when air conditioning is running.◆ Please read the air conditioning user manual for more details.
<p>Screws (every year)</p> <ul style="list-style-type: none">◆ Check whether the screws inside the outdoor battery cabinet and the PCS are dropped.
<p>Device maintenance (every six months)</p> <ul style="list-style-type: none">◆ Perform routine checking for corrosion of all metal components.◆ Check running parameters (especially voltage and insulation, etc.).

The table shows only recommended routine maintenance intervals. The actual maintenance cycle should be reasonably determined in combination with the specific installation environment of the product.

Factors such as location and site environment will affect the maintenance cycle of the product. If the running environment is windy and sandy or the dust is thick, it is necessary to shorten the maintenance cycle and increase the maintenance frequency.

12.3 System Cleaning

12.3.1 Overview

Cleaning around and inside the outdoor battery cabinet and PCS is an important part of maintenance work.

Due to the influence of temperature, humidity, dust and vibration of internal equipment in the environment where the outdoor battery cabinet and PCS are located, dust will accumulate inside, block the air inlet and outlet or enter the internal equipment, which will lead to potential failure of the internal equipment and shorten the service life of the equipment or reduce power generation.

During the normal operation of the equipment, inspection and cleaning work should be carried out regularly to ensure that the internal equipment is in a relatively good running environment to a certain extent.

12.3.2 Cleaning Cycle

The cleaning cycle of outdoor battery cabinets and ESS should be reasonably determined in combination with their running environment, such as climatic conditions, to ensure that the external and internal cleanliness of outdoor battery cabinet and PCS are in good condition. If the running environment is relatively harsh, such as desert areas, the maintenance cycle should be shortened.

12.3.3 Internal Cleaning

For the dust inside the integrated ESS, it is not recommended to use a broom to clean it directly, or it will easily cause flying dust. It is recommended to use a vacuum cleaner to absorb the dust. It is recommended to clean the air conditioner condenser every 6 months.

12.3.4 Internal Cleaning of the Foundation

Users should regularly enter the foundation to check the cleanliness. Clean with a vacuum cleaner if necessary.

12.3.5 Checking Door Locks and Hinges

After cleaning, check whether the door locks and hinges of the integrated ESS can be used normally and are in good condition.

If necessary, the door lock holes and hinges should be properly lubricated.

12.3.6 Checking Sealing Strips

Good sealing strips are important guarantee to effectively prevent water seepage inside the outdoor battery cabinet and PCS. It should be carefully inspected and replaced immediately if damaged.

12.4 Paint Touch-up Measures

Check the exterior damage of the outdoor battery cabinet and PCS:

- Surface dirt caused by water stains and dust can be cleaned:
 1. Use a rag (or other cleaning tool) to scrub dirty surfaces.
 2. If it cannot be scrubbed clean with water, try to scrub with alcohol or other non-corrosive detergents.



- Dirty surface & damaged finish, surface marks can't be cleaned
 1. After cleaning with detergent, when you find scratches or paint peeling on the surface, you should use sandpaper to smooth the part.



2. After polishing, clean it again with detergent. After drying, use a brush to touch up the paint, the paint number is light gray RAL7035. When touching up, try to keep the touch-up part uniform.



14 Appendix

14.1 System Wiring Diagram

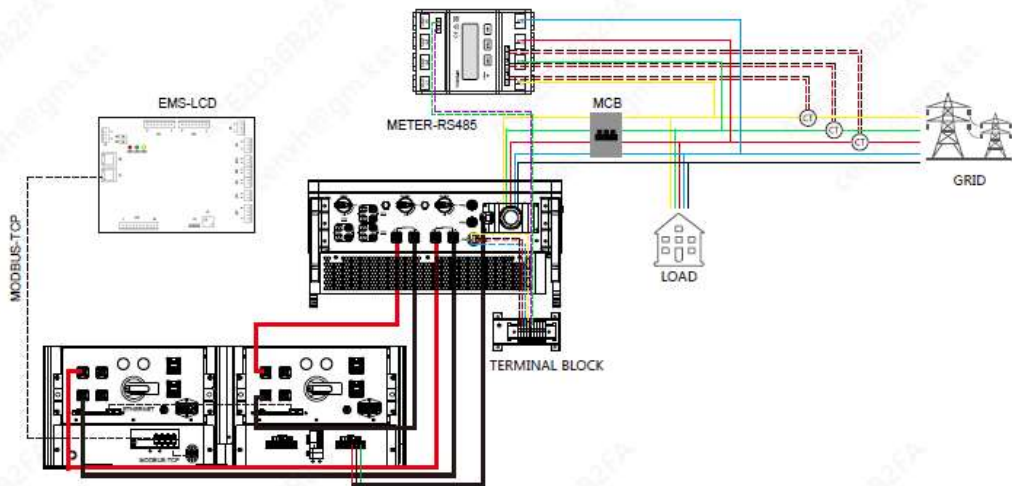

14.2 Single System Parameters

Model	KAC50DP-BC100DE
Parameters	
Rated power	50 kW
Total current waveform distortion rate	< 3% (at rated power)
DC component	< 0.5% (at rated power)
Rated grid voltage	400 V
Grid voltage range	340~440V
Rated grid frequency	50/60 Hz
Grid frequency range	45~55Hz/55~65Hz
Isolation method	Non-isolation
Converter size (W×H×D)	650*810*324mm
Weight	75 kg
Degree of protection	IP65
Communication interface	RS485, CAN
Battery type	Lithium iron phosphate
Battery module	5.1 kWh, 44 kg
Number of battery modules	20
Rated capacity of battery	102.4kWh
Rated voltage of battery	512V
Charge and discharge rate	≤0.5C
Depth of discharge	100%
Battery cabinet dimensions (W×H×D)	1100×2380×1100mm
Battery cabinet weight	1500 kg
Degree of protection	IP54
Working humidity range	0%~100% (non-condensing)
Running temperature range	-25℃~+60℃ (derating when >45℃)
Cooling method	Wall mounted air conditioning, air-cooled

14.3 Tightening Torques

In order to prevent the wiring copper nose from loosening due to force, causing poor contact, or increasing contact resistance, causing heat or even fire, it is necessary to ensure that the following torque requirements are met when tightening the screws of the wiring copper nose:

Unit: (N·m)

Screw size	Torque	Screw size	Torque
M3	0.7~1	M8	18~23
M4	1.8~2.4	M10	34~40
M5	4~4.8	M12	60~70
M6	7~8	M16	119~140

To reduce the stress on the copper lugs, the cables should be fixed at appropriate locations.

14.4 First Run Parameter Settings

1. Set the system time according to local time:

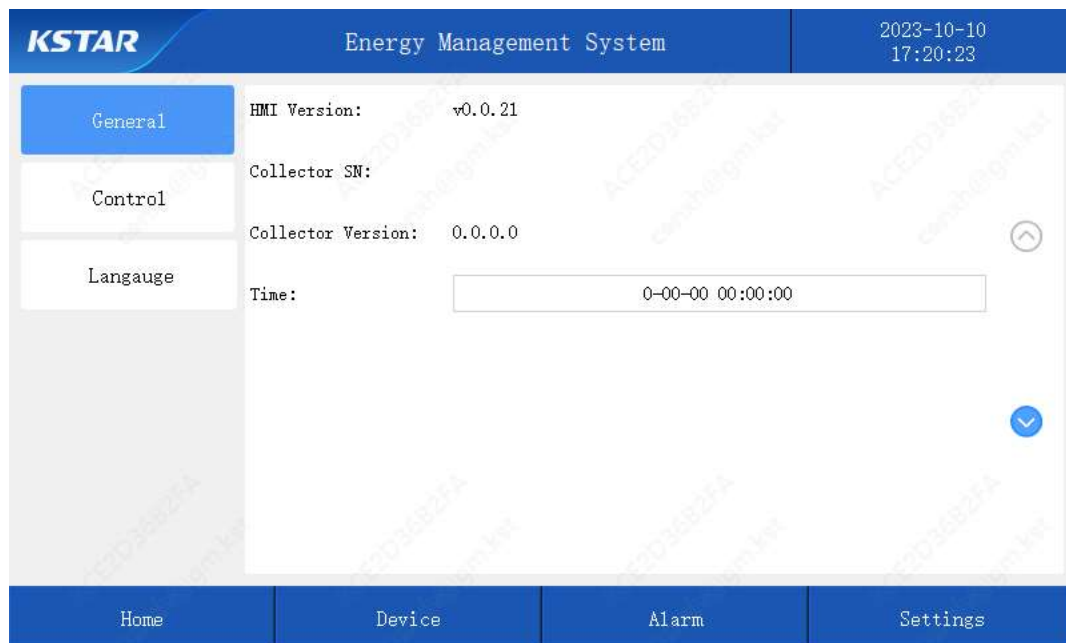

2. Set the grid type:

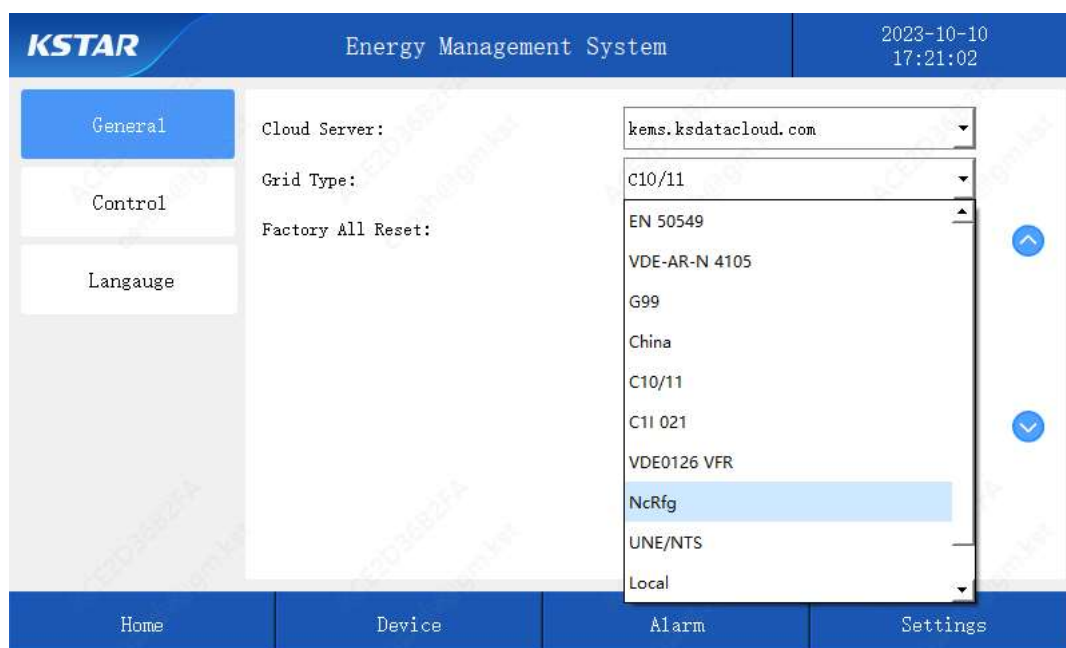

3. Select the Running mode:

The screenshot shows the 'Running Mode' configuration page in the KSTAR Energy Management System. The interface includes a sidebar with 'General', 'Control', and 'Language' options. The main content area has tabs for 'Basic' and 'Running Mode'. Under 'Running Mode', there is a 'Battery Backup' dropdown menu, a radio button for 'Demand Ctrl' with a 'Value(kW)' input field, and an 'SOC(%)' input field. The bottom navigation bar contains 'Home', 'Device', 'Alarm', and 'Settings'.

If timesharing control is selected, it is also necessary to set the timesharing power:

The screenshot shows the 'Timesharing Control' configuration page in the KSTAR Energy Management System. The interface includes a sidebar with 'General', 'Control', and 'Language' options. The main content area has a dropdown menu for 'Monday' with '(Positive discharge, Negative charge.)' text, and 'Copy' and 'Back' buttons. Below are multiple rows of 'Start Time', 'End Time', and 'Power (kW)' input fields. The bottom navigation bar contains 'Home', 'Device', 'Alarm', and 'Settings'.

4. Enable battery SOC control and set SOC differential (%) value:

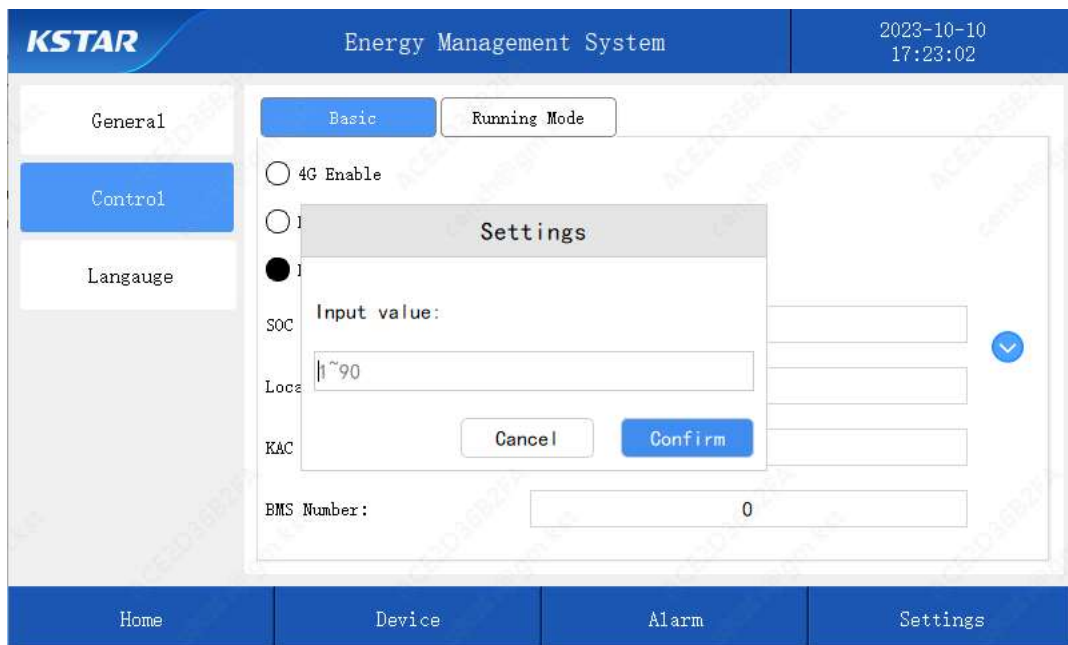

5. Click the power on button in Device-KAC-On/Off:

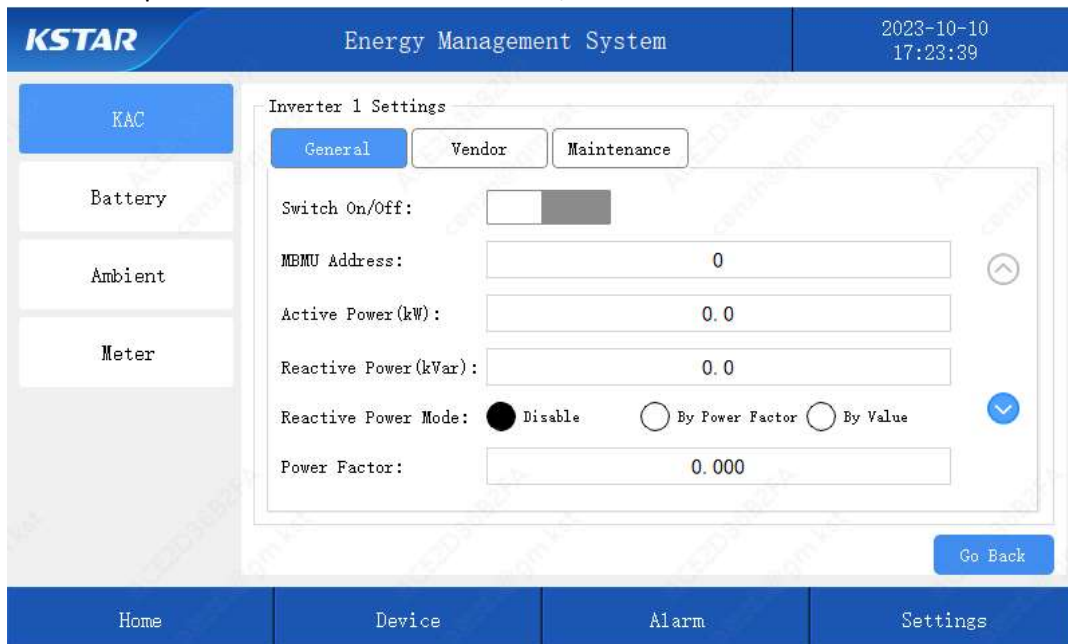

14.5 Quality Assurance

For products that fail during the warranty period, Shenzhen Kstar New Energy Co., Ltd. (the “Company”) will repair or replace new products free of charge. During the warranty period, the Company will ask the customer to show the invoice and date of purchase of the product. In addition, the trademark on the product should be clearly visible, or we have the right not to provide quality assurance.

- Replaced defective products shall be handled by our company
- Customers should allow us reasonable time to repair malfunctioning equipment

In the following situations, the warranty is invalid:

- Shipping damage Free warranty period of the machine and components has expired
- Transport damage
- Improper installation, modification or use
- Operation in very harsh environments beyond those described in this manual
- Machine failure or damage caused by installation, repair, modification or disassembly by service agencies or personnel other than our company
- Beyond the installation and use scope specified in relevant international standards
- Damage caused by abnormal natural environment

If the product failure occurs due to the above conditions and the customer requires maintenance services, we can provide charged maintenance services after confirmation by our service organization.

The product dimensions and parameters are subject to change without prior notice.

14.6 Contact Information

If you have any questions about this product, please contact us. In order to provide you with faster and better service, we need your assistance to provide the following information:

- Equipment model
- Number
- Fault code/name
- Brief description of the fault

Shenzhen Kstar New Energy Co., Ltd.

Address: Kstar Industrial Park, No. 7 Road, West High-tech Park, Guangming District, Shenzhen

Zip code: 518106

After-sales service hotline: 400-700-9662

Headquarters Tel: 0755-2138 9008

Website: www.kstar.com

E-mail: service@kstar.com.cn

※The product dimensions and parameters are subject to change without prior notice