

# DTSD1352



## General

DTSD1352 is a smart meter designed for power supply system, industrial and mining enterprises and utilities to calculate the electricity consumption and manage the electric demand. It features the high precision, small size and simple installation. It integrates the measurement of all electrical parameters with the comprehensive electricity metering and management provides various data on previous 12 months, checks the 31st harmonic content and the total harmonic content, realizes the remote communication and the remote control with switching input and relay output and boasts the alarm output. It is fitted with RS485 communication port and adapted to MODBUS-RTU. DTSD1352 can be used in all kinds of control systems, SCADA systems and energy management systems. All meters meet the related technical requirements of electronic power meter in the IEC62053-21、IEC62053-22 standards.

## Type Description

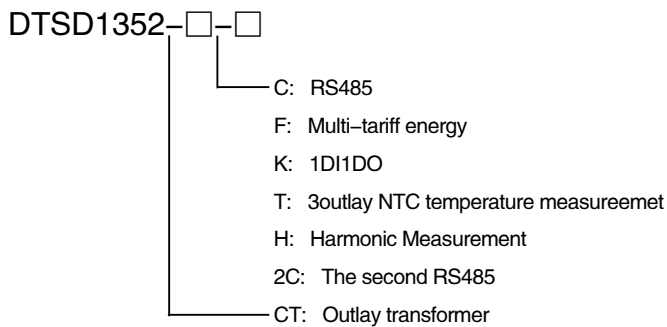

## Function Description

Function	Function description	Function provide
Measurement of kWh	Active kWh (positive and negative)	■
	Reactive kWh (positive and negative)	■
	A, B, C phase positive active kWh	■
Measurement of electrical parameters	U、IP、Q、S、PF、F	■
Measurement of	2-31ST Voltage and current harmonic	□ Note 1
LCD Display	8 bits section LCD display, background light	■
Key programming	4 keys to communication and set parameters	■

Function	Function description	Function provide
Pulse output	Active pulse output	■
	Reactive pulse output	□ Note 2
	Clock pulse output	□ Note 2
LED alarm	Alarm on voltage loss and overvoltage	■
Multi-tariff and functions	Active switch input	□ Note 3
	Switch output	□ Note 2
	Adapt 4 time zones, 2 time interval lists, 14 time interval by day and 4 tariff rates	□
	Max demanded kWh and time happened	□
	Frozen data on last 48 months, last 90days	□
	Date, time	□
Communication	Infrared communication	■
	The first communication path: Communication interface: RS485, Communication protocol:	□
	The second communication path: Communication interface: RS485, Communication protocol: MODBUS-RTU	□ Note 3
Temperature measurement	Support 3 outlay NTC temperature	□ Note 4

Note:

1. Harmonic is a standard while choosing outlay transformer, optional for other situation.
2. Reactive pulse output, clock pulse output and switching output: Choose one of these three.
3. Active switching, the second communication path: Choose one of these two.
4. Both 1 and 2 cannot be chosen while choosing temperature measurement.

## Technical Parameter

Specification	3 phase 3 wires, 3 phase 4 wires	
Voltage	Reference voltage	3 × 100V、3 × 380V、3 × 57.7/100V、3 × 220/380V
	Consumption	<10VA(Single phase)
	Impedance	>2MΩ
	Accuracy class	Error ± 0.2%
Current	Input current	3 × 1(6)A, 3 × 1(6)A()(Outlay transformer), 3 × 10(80)A
	Consumption	<1VA(Single phase rated current)
	Accuracy class	Error ± 0.2%
Power	Active, reactive, apparent power, error ± 0.5 %	
Frequency	45 ~ 65Hz, Error ± 0.2%	
Temperature	-40℃ ~ 99℃	
Energy	Active energy(Accuracy class:0.5, 1),	
	reactive energy(Accuracy class 2)	
Clock	≤0.5s/d	
Energy pulse output	1 active optocoupler output,	
	1 reactive optocoupler output	
Switching output	1 Switching output	
Switching input	1 optocoupler input	

Width of pulse	80 ± 20ms
Pulse constant	6400imp/kWh, 400imp/kWh (Correspond with the basic current)
Interface and communication	RS485: Modbus RTU
Range of communication address	Modbus RTU: 1~ 247;
Baud rate	1200bps~19200bps
Relative temperature	-25°C~+55°C
Relative humidity	≤95% (No condensation)

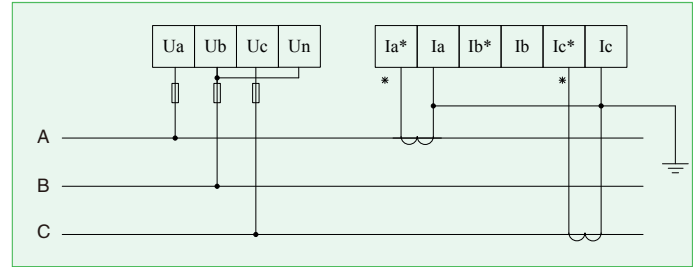

Fig 4 Three phase three lines connect via CT

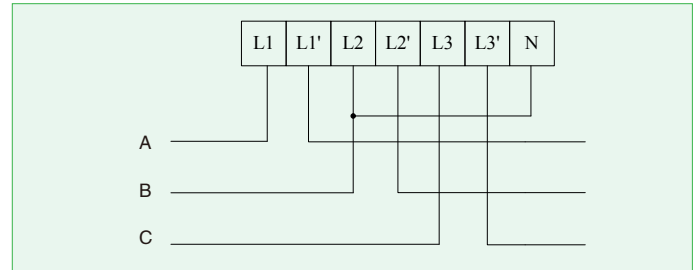

Fig 5 Three phase three lines direct connect

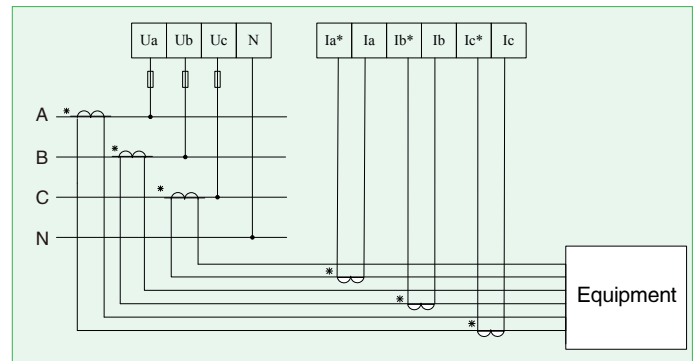

Fig 6 Three phase four lines, 3CT

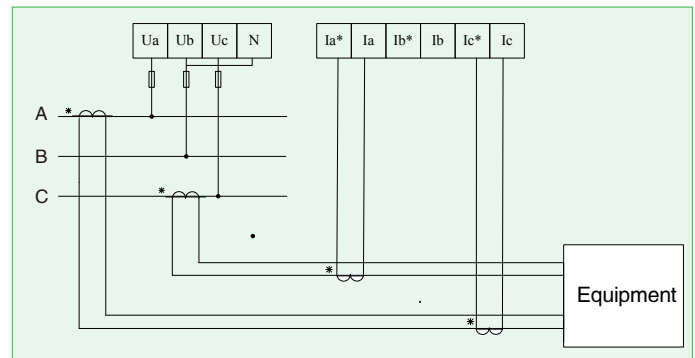

Fig 7 Three phase three lines, 2CT

### Dimension Drawings

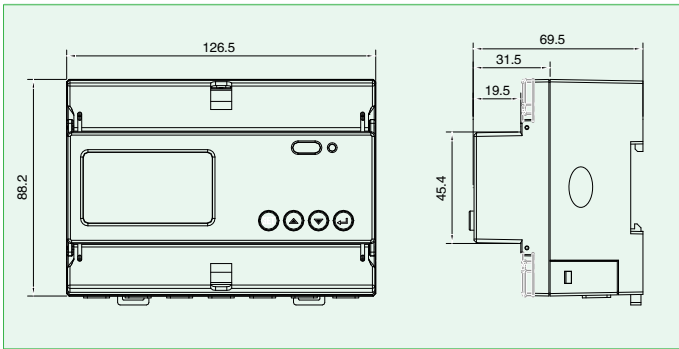

Fig 1 Outline (unit: mm)

### Wiring and Installing

#### ■ Wiring sample of voltage and current

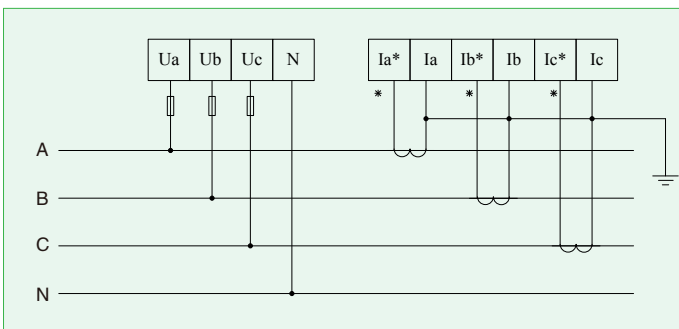

Fig 2 Three phase four lines connect via CT

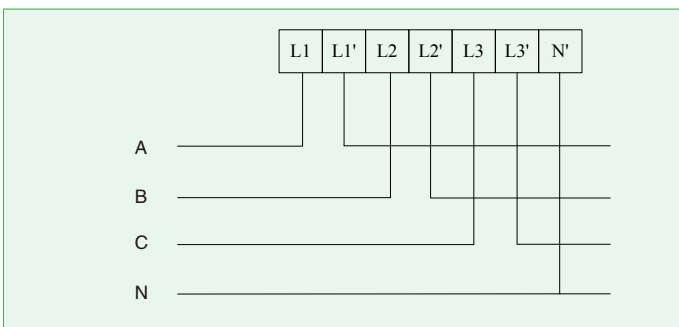

Fig 3 Three phase four lines direct connect

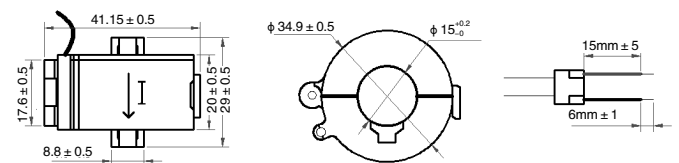

Fig 8 Outline of transformer

### ■ witching input, output, NTC temperature measurement.

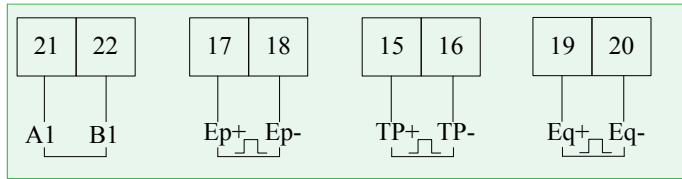

Fig 9 Communication, pulse connection

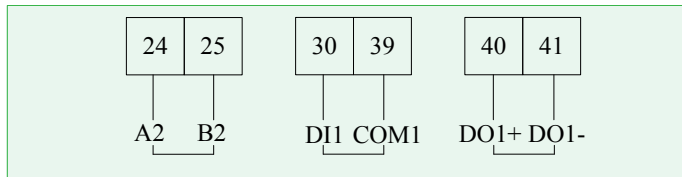

Fig 10 Communication, pulse connection

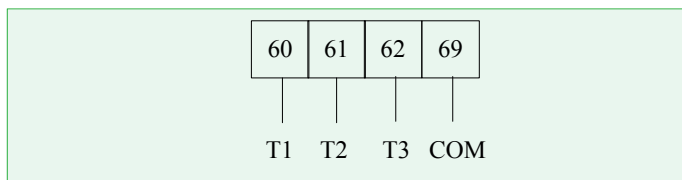

Fig 11 Outlay NTC temperature measurement

Switching output is relay output, can achieve the remote-control and alarm output.

The switch input adapts the method of on-off signal input and powered by outer power supply. It can be gotten by meter when there is a change of on or off via a switching input module. The parameter of switching input can not only get and show the state of local switching information but also achieve the communication via RS485, which called "remote information" function.

Note:

- (17-18) are active energy pulse,
- (60,61,62,69) are NTC temperature measurement port,
- (15,16) are clock pulse,
- (19,20) are reactive energy pulse,
- (40,41) are switch output and multiplex with (60,61),
- (24,25) are 2 path of communication,
- (31,32) are switch input and multiplex with (62,69).

## Function Description

### ■ Measurement

The meter can measure all electrical parameters such as voltage, current, active power, reactive power, apparent power, power factor, frequency, 31st harmonic and total harmonic. The value format of voltage, current, frequency and power are listed as below.

Example:  $U = 220.1V$ ,  $f = 49.98Hz$ ,  $I = 1.99A$ ,  $P = 0.439kW$

### ■ Calculating

The meter can calculate the current active energy, forward active energy, reversing active energy, forward reactive energy and reversing reactive energy.

### ■ Timing

The meter has 2 time lists, and can be divided into 4 time zones per year. Each time list can be divided into 8 time periods and 4 tariff (F1、F2、F3、F4). The main purpose of multi-tariff is promote the energy efficiency and economic benefits.

### ■ Demand

There are some definitions on demand:

Demand	The average power in the demand cycle.
Maximum demand	The maximum value of demand in a period of time.
Demand cycle	The time period between two same average value of demand.

The default demand cycle is 15 minutes, slip time is 1 minute.

The meter can measure 4 kinds of maximum demand: forward active, reversing active, inductance performance reactive, capacitance performance reactive maximum demand and the occur time.

### ■ History data statistics

The meter can record last 48 months or last 90 days history energy in each tariff.

### ■ Switching input and output

The switch input adapts the method of on-off signal input and powered by outer power supply. It can be gotten by meter when there is a change of on or off via a switching input module. The parameter of switching input can not only get and show the state of local switching information but also achieve the communication via RS485, which called "remote information" function.

### ■ Temperature measurement

The meter support three path of outlay NTC temperature measurement, the range of temperature is  $-40^{\circ}C \sim 99^{\circ}C$ .

### Operation and Display

#### Key function description

Key symbol	Key name	Function
	Menu	Enter/quit menu
	Voltage and current, up	Check the voltage and current Leftward and change flash in programming menu
	Power, down	Check the power Rightward and change the value on flash
	Energy, enter	Check the energy Enter in programming menu

#### Display menu

The meter will show the forward active energy after powering. The customers can change the information showing by pressing the keys. The menu description is listed as below:

Key symbol	Function
	Voltage on A, B, C phase, Current on A, B, C phase, Frequency, Date, Time, Address, Version, Test on display
	Total active/reactive/apparent power and on A, B, C phase, Total power factor and on A, B, C phase, Forward/reversing active/reactive maximum demand
	Total forward/reserving active/reactive energy, forward/reserving active/reactive spike/peak/flat/valley energy, forward active energy on A, B, C phase.

Note:

- All the display menus above are in the model of ADL3000 three phases four lines with multi-tariff rate function and can be changed by the keys.
- There will not be power or power factor on each phase and will only show total power and power factor (Active, reactive, apparent) under the three phase three lines.
- There will not be date, time, maximum demand and energy by time without the function of multi-tariff rate.



Current forward active energy 12.34kWh

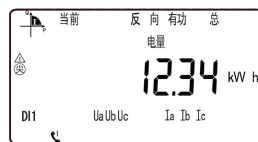

Current reversing active energy 12.34kWh



Current forward reactive energy 12.34kWh



Current forward active energy 12.34kWh



Current power is 1.234kW



Current forward active demand is 1.234kW



Voltage on A phase is 123.4V



Current on A phase is 12.34A

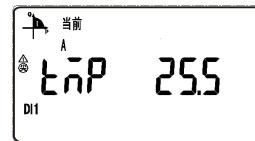

Voltage on A phase is 123.4V

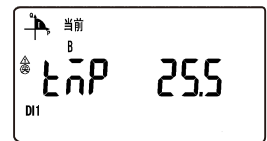

Temperature on T2 is 25.5 cent degree



Voltage on A phase is Temperature on T3 is 25.5 cent degree123.4V

Note: There are parts of the display function, and other menus are familiar with the example above. The customers can understand the meaning refer to the above examples.

#### Key menu

Press at any main menu and get in "PASS" interface, and then press show "0000", and enter the code. If you enter a wrong code, it will show "fail" and back to main menu; and if you enter a right code, you can set the parameter. After setting the parameter and press , it will show "save" and save the change by pressing in "yes" interface and quit without save by pressing in "no" interface.

#### Data settings

First menu		Second menu		
Symbol	Mean	Symbol	Mean	Range
BUS	Communi- cation settings	ADDR	Address setting	1-247
		Buad	Baud rate	19200、9600、4800、 2400、1200
SyS	System settings	Parity	Parity	None、Even
		PL	Network	3P4L:3 phase 4 lines 3P3L:3 phase 3 lines
		EF.E	Multi-tariff rate	EF:Multi-tariff rate E:No multi-tariff rate
		CoDE	Code setting	1-9999
		LED	Time of light	1-9999
In.	Transform er settings	Pt	Voltage transformer	1-9999
		Ct	Current transformer	1-9999

Note: Customers can choose None or Even under Modbus protocol.