

Preventive Maintenance Manual

PV Grid-Connected Inverter

SG285HX / SG320HX / SG333HX / SG350HX



All Rights Reserved

All Rights Reserved

No part of this document can be reproduced in any form or by any means without the prior written permission of Sungrow Power Supply Co., Ltd (hereinafter "SUNGROW").

Trademarks

SUNGROW and other SUNGROW trademarks used in this manual are owned by SUNGROW.

All other trademarks or registered trademarks mentioned in this manual are owned by their respective owners.

Software Licenses

- It is prohibited to use data contained in firmware or software developed by SUNGROW, in part or in full, for commercial purposes by any means.
- It is prohibited to perform reverse engineering, cracking, or any other operations that compromise the original program design of the software developed by SUNGROW.

About This Manual

The manual mainly contains the product information, as well as guidelines for installation, operation, and maintenance. The manual does not include complete information about the photovoltaic (PV) system. Readers can get additional information at www.sungrowpower.com or on the webpage of the respective component manufacturer.

Validity

This manual is valid for the following model of low-power grid-connected PV string inverters:

- SG285HX
- SG320HX
- SG333HX
- SG350HX

It will be referred to as "inverter" hereinafter unless otherwise specified.

How to Use This Manual

Please read this manual carefully before using the product and keep it properly at a place for easy access.

All contents, pictures, marks, and symbols in this manual are owned by SUNGROW. No part of this document may be reprinted by the non-internal staff of SUNGROW without written authorization.

Contents of this manual may be periodically updated or revised, and the actual product purchased shall prevail. Users can obtain the latest manual from support.sungrowpower.com or sales channels.

Security Declaration

For details on the product's network security vulnerability response process and vulnerability disclosure, please visit the following website: <https://en.sungrowpower.com/security-vulnerability-management>.

For more information on network security, please refer to the user manual of the communication module or the Data Logger that comes with the product.

Symbols

This manual contains important safety instructions, which are highlighted with the following symbols, to ensure personal and property safety during usage, or to help optimize the product performance in an efficient way.

Please carefully understand the meaning of these warning symbols to better use the manual.

 **DANGER**

Indicates high-risk potential hazards that, if not avoided, may lead to death or serious injury.

 **WARNING**

Indicates moderate-risk potential hazards that, if not avoided, may lead to death or serious injury.

 **CAUTION**

Indicates low-risk potential hazards that, if not avoided, may lead to minor or moderate injury.

NOTICE

Indicates potential risks that, if not avoided, may lead to device malfunctions or financial losses.



“NOTE” indicates additional information, emphasized contents or tips that may be helpful, e.g., to help you solve problems or save time.

Contents

All Rights Reserved.....	I
About This Manual.....	II
1 System Introduction.....	1
2 Safety Instructions.....	3
2.1 Electrical Connection Safety.....	4
2.2 Operation Safety.....	7
2.3 Maintenance Safety.....	7
3 Pre-inspection Preparation.....	9
3.1 PPE.....	9
3.2 Inspection Tools.....	10
3.3 Inspection Personnel Requirements.....	11
4 Inverter Inspection.....	12
4.1 Inspection Checklist.....	12
4.2 Inspection Instructions.....	17
4.2.1 Check Installation Reliability.....	17
4.2.2 Check Product Labels and Signs.....	18
4.2.3 Check DC Cables.....	19
4.2.4 Check AC Cables.....	20
4.2.5 Clean Air Outlets and Heat Sink Fins.....	21
4.2.6 Fan Maintenance.....	23
4.2.7 Check Temperature.....	25
4.2.8 Check Emergency Stop Function.....	27
4.3 Inspection (via iSolarCloud or Logger).....	27
4.3.1 Inspection Checklist.....	27
4.3.2 iSolarCloud App.....	27
4.3.3 Check Firmware Version.....	36
4.3.4 Check Parameter Settings.....	39

5 MVS Inspection	43
5.1 Inspection Checklist.....	43
5.2 Check System Status.....	44
5.3 Check Appearance.....	45
5.4 Check System Cleanliness.....	46
6 Transformer Inspection	48
6.1 Inspection Checklist.....	48
6.2 Check the External Condition of the Transformer.....	49
6.3 Check Cable Connections.....	52
6.4 Check the Transformer Protection Status.....	53
7 Ring Main Unit Inspection	54
7.1 Inspection Checklist.....	54
7.2 Check Cleanliness.....	55
7.3 Check Cable Connections.....	55
7.4 Check Switch Function.....	59
7.5 Check Relay Protection Function (Optional).....	59
8 Foundation Inspection	61
8.1 Check the Foundation Structure.....	61
8.2 Check Product Fixation.....	61
9 Appendixes	63
9.1 Inverter Power-on.....	63
9.1.1 Inspection Before Power-on.....	63
9.1.2 Power-on Steps.....	63
9.2 Disconnecting the Inverter.....	64

1 System Introduction

The inverter is a transformerless 3-phase PV grid-connected inverter. As an integral component in the PV power system, the inverter is designed to convert the direct current power generated from the PV modules into grid-compatible AC current and to feed the AC current into the utility grid.

⚠ WARNING

Do not connect any local load between the inverter and the AC circuit breaker except for the tracking axis.

NOTICE

When designing the system, ensure that the operating ranges of all devices that are connected to the inverter meet the requirements of the inverter.

The PV modules in the system must comply with the IEC 61730-1 (2016) class II standard.

The inverter is only applicable to the scenarios described in the manual and cannot be used in other situations.

The intended usage of the inverter is illustrated in the following figure.

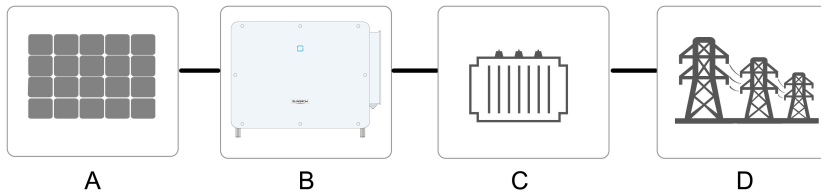
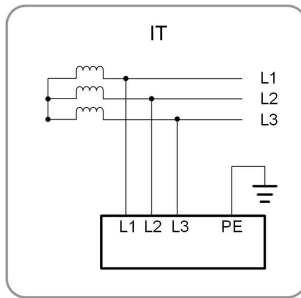

figure 1-1 Inverter Application in PV Power System

Item	Description	Note
A	PV strings	Monocrystalline silicon, polycrystalline silicon and thin-film without grounding
B	Inverter	SG285HX / SG320HX / SG333HX / SG350HX
C	Transformer	Raises the output voltage of the inverter to a level that meets the requirements of the grid
D	Utility grid	The grid form supported by the inverter is shown in the figure below



2 Safety Instructions

When installing, commissioning, operating, and maintaining the product, strictly observe the labels on the product and the safety requirements in the manual. Incorrect operation or work may cause:

- Injury or death to the operator or a third party.
- Damage to the product and other properties.

WARNING

- **Do not perform any operation on the product (including but not limited to, handling, installing, powering on, or maintaining the product, performing electrical connection, and working at heights) in harsh weather conditions, such as thunder and lightning, rain, snow, and Level 6 or stronger winds. SUNGROW shall not be held liable for any damage to the device due to force majeure, such as earthquakes, floods, volcanic eruptions, mudslides, lightning strikes, fires, wars, armed conflicts, typhoons, hurricanes, tornadoes, and other extreme weathers.**
- **In case of fire, evacuate from the building or product area and call the fire alarm. Re-entry into the burning area is strictly prohibited under any circumstances.**

NOTICE

- **Tighten the screws with the specified torque using tools when fastening the product and terminals. Otherwise, the product may be damaged. And the damage caused is not covered by the warranty.**
- **Learn how to use tools correctly before using them to avoid hurting people or damaging the device.**
- **Maintain the device with sufficient knowledge of this manual and use proper tools.**



- The safety instructions in this manual are only supplements and cannot cover all the precautions that should be followed. Perform operations considering actual onsite conditions.
- SUNGROW shall not be held liable for any damage caused by violation of general safety operation requirements, general safety standards, or any safety instruction in this manual.
- When installing, operating, and maintaining the product, comply with local laws and regulations. The safety precautions in this manual are only supplements to local laws and regulations.
- During the product transport, installation, wiring, maintenance, etc., the materials and tools prepared by users must meet the requirements of applicable local laws and regulations, safety standards, and other specifications. SUNGROW shall not be held liable for any damage to the product caused by the adoption of materials and tools that fail to meet the above-mentioned requirements.
- Operations on the product, including but not limited to, handling, installing, wiring, powering on, maintenance, and use of the product, must not be performed by unqualified personnel. SUNGROW shall not be held liable for any damage to the product resulting from operations done by unqualified personnel.
- Where the transport of the product is arranged by users, SUNGROW shall not be held liable for any damage to the product that is caused by users themselves or the third-party transport service providers designated by the users.
- SUNGROW shall not be held liable for any damage to the product caused by the negligence, intent, fault, improper operation, and other behaviors of users or third-party organizations.
- SUNGROW shall not be held liable for any damage to the product arising from reasons unrelated to SUNGROW.

2.1 Electrical Connection Safety



DANGER

- **Before electrical connections, please make sure that the inverter is not damaged, otherwise it may cause danger!**
- **Before electrical connections, please make sure that the inverter switch and all switches connected to the inverter are set to "OFF", otherwise electric shock may occur!**

 DANGER

The PV string will generate lethal high voltage when exposed to sunlight.

- Operators must wear proper personal protective equipment during electrical connections.
- Must ensure that cables are voltage-free with a measuring instrument before touching DC cables.
- Respect all safety instructions listed in relevant documents about PV strings.
- The inverter must not be connected to a PV string that requires positive or negative grounding.

 DANGER

Danger to life due to a high voltage inside the inverter!

- Be sure to use special insulation tools during cable connections.
- Note and observe the warning labels on the product, and perform operations strictly following the safety instructions.
- Respect all safety instructions listed in this manual and other pertinent documents.

 WARNING

Damage to the product caused by incorrect wiring is not covered by the warranty.

- Electrical connection must be performed by professionals.
- All cables used in the PV generation system must be firmly attached, properly insulated, and adequately dimensioned.

⚠ WARNING

- Check the positive and negative polarity of the PV strings, and connect the PV connectors to corresponding terminals only after ensuring polarity correctness.
- During the installation and operation of the inverter, please ensure that the positive or negative poles of PV strings do not short-circuit to the ground. Otherwise, an AC or DC short-circuit may occur, resulting in equipment damage. The damage caused by this is not covered by the warranty.
- Do not connect any load between the inverter and the AC circuit breaker directly connected to it, so as to prevent the switch from tripping by mistake.
- Determine the specifications of AC circuit breakers strictly in compliance with the applicable local laws and regulations and safety standards or the recommendation by SUNGROW. Otherwise, the switch may not open in time in the event of something abnormal, which may then lead to safety incidents.

NOTICE

Comply with the safety instructions related to PV strings and the regulations related to the local grid.

2.2 Operation Safety

DANGER

When routing cables, ensure a distance of at least 30 mm between the cables and heat-generating components or areas to protect the insulation layer of cables from aging and damage.

When the product is working:

- Do not touch the product enclosure.
- It is strictly forbidden to plug and unplug any connector on the inverter.
- Do not touch any wiring terminal of the inverter. Otherwise, electric shock may occur.
- Do not disassemble any parts of the inverter. Otherwise, electric shock may occur.
- It is strictly forbidden to touch any hot parts of the inverter (such as the heat sink). Otherwise, it may cause burns.
- Do not connect or remove any battery. Otherwise, electric shock may occur.
- Do not connect or remove any PV string or any PV module in a string. Otherwise, electric shock may occur.
- If the inverter is equipped with a DC switch, do not operate it. Otherwise, it may cause device damage or personal injury.

Do not take other actions, such as setting parameters or cutting off power, during the process of inverter firmware update, to avoid update failure.

2.3 Maintenance Safety

DANGER

Risk of inverter damage or personal injury due to incorrect service!

- Before maintenance, disconnect the AC circuit breaker on the grid side and then the DC switch. If a fault that may cause personal injury or device damage is found before maintenance, disconnect the AC circuit breaker and wait until the night before operating the DC switch. Otherwise, a fire inside the product or an explosion may occur, causing personal injuries.
- After the inverter is powered off for 25 minutes, measure the voltage and current with professional instrument. Only when there is no voltage nor current can operators who wear protective equipment operate and maintain the inverter.
- Even if the inverter is shut down, it may still be hot and cause burns. Wear protective gloves before operating the inverter after it cools down.

 DANGER

Touching the power grid or the contact points and terminals on the inverter connected to the power grid may lead to electric shock!

- The power grid side may generate voltage. Always use a standard voltmeter to ensure that there is no voltage before touching.

 CAUTION

To prevent misuse or accidents caused by unrelated personnel, post prominent warning signs or demarcate safety warning areas around the product.

NOTICE

To avoid the risk of electric shock, do not perform any other maintenance operations beyond this manual. If necessary, contact SUNGROW for maintenance. Otherwise, the losses caused is not covered by the warranty.

NOTICE

- If the paint on the inverter enclosure falls or rusts, repair it in time. Otherwise, the inverter performance may be affected.
- Do not use cleaning agents to clean the inverter. Otherwise, the inverter may be damaged, and the loss caused is not covered by the warranty.
- As the inverter contains no parts that can be maintained, never open the enclosure of the inverter or replace any internal components without authorization. Otherwise, the loss caused is not covered by the warranty.
- Do not open the maintenance door in rainy or snowy weather. If it is inevitable, take proper protective measures to avoid the ingress of rainwater and snow into the maintenance compartment; otherwise, the product's operation may be affected.
- Before closing the maintenance door, check whether there is any object left inside the maintenance compartment, such as screws, tools, etc.
- It is recommended for users to use cable sheathing to protect the AC cable. If the cable sheathing is used, make sure it is positioned inside the maintenance compartment.

3 Pre-inspection Preparation

3.1 PPE

Protective equipment includes personal protective equipment (PPE) and electrical safety equipment (ESE).

PPE

Be sure to wear the following PPE that meets local regulatory requirements for equipment inspection operations.

tools		
		
Fluorescent vest	Safety gloves	Safety helmet
		
Safety goggles	Noise reduction earplugs	Safety shoes

ESE

If working on live equipment, ensure that there are at least two operators on site and prepare the following ESE to ensure personal safety.

tools



Rescue rod



Insulated stool



Face shield

3.2 Inspection Tools

Using safe, reliable, well-maintained, and valid inspection tools is essential for ensuring the normal operation of equipment and personal safety.

table 3-1 Examples of inspection tools

tools



Clamp-on ammeter



1500VDC multimeter



Phase rotator

tools



Screwdriver



Wrench set



Torque wrench



Blower



Soft bristle brush

3.3 Inspection Personnel Requirements

- Possess a valid low voltage electrical work permit as required by the country/region where the site is located.
- Possess certain knowledge in electronics, electrical wiring, and mechanics, and be familiar with electrical and mechanical schematics.
- Have received professional training related to electrical equipment installation and trial operation.
- Be capable of addressing dangers or emergencies that may arise during installation or trial operations.
- Be familiar with local standards and relevant safety regulations for electrical systems.
- Thoroughly read this manual and understand the relevant safety precautions.

4 Inverter Inspection

4.1 Inspection Checklist

table 4-1

No	Type	Details	Inspection Interval
1	Installation reliability inspection	Carefully check if the bolts of the mounting brackets show signs of loosening or wear. If loose, use a torque wrench to tighten the bolts at the standard torque of 35N.m.	Once a year
2	Equipment label inspection	Carefully check if the warning labels on the equipment are clearly visible. If any labels are faded, blurred, or the text on them is illegible, they need to be replaced promptly.	Once a year

No	Type	Details	Inspection Interval
3	DC cable inspection	<ol style="list-style-type: none"><li data-bbox="715 256 967 629">1 Check if the unused DC input terminals of the inverter are sealed with plugs. If not, use the blue plugs provided with the inverter to seal the terminals.<li data-bbox="715 629 967 1001">2 Check if the DC input terminals are deformed due to the tension of the DC cables. If this is the case, replace the cables and increase their length.<li data-bbox="715 1001 967 1295">3 Please inspect the cables for damage, particularly the sections in contact with the metal enclosure.<li data-bbox="715 1295 967 1585">4 Use a thermal imager to scan the DC terminals. If the temperature is abnormal, replace the DC input terminals.	Once every six months or as needed

No	Type	Details	Inspection Interval
4	AC cable inspection	<ol style="list-style-type: none"> <li data-bbox="763 270 986 480">1 Check if the cable inlet is sealed properly. If necessary, re-seal the cable inlet. <li data-bbox="763 499 986 852">2 Check if the fixing bolts of the AC wiring terminals are loose. If any terminals are loose, tighten them with a socket at a torque of 20-30N.m after powering off. <li data-bbox="763 872 986 1323">3 Check if the grounding wire on the AC side is loose or detached. Tighten the fixing bolts with an appropriately sized socket. If loose or detached, re-crimp the OT terminal of the grounding wire. <li data-bbox="763 1342 986 1587">4 Please inspect the cables for damage, particularly the sections in contact with the metal enclosure. <li data-bbox="763 1607 986 1952">5 During operation, use a thermal imager to check the temperature of AC terminals. If abnormal, power off, tighten bolts, and re-crimp DT terminals. 	Once every six months or as needed

No	Type	Details	Inspection Interval
5	Clean air outlets	<ol style="list-style-type: none"><li data-bbox="725 256 949 472">1 Check the inverter's temperature and for dust. Clean the inverter's enclosure if necessary.<li data-bbox="725 472 949 844">2 To maintain good ventilation, ensure the air inlets and outlets are not blocked. If necessary, clean the air inlets and outlets with a soft brush or vacuum cleaner.<li data-bbox="725 844 949 1177">3 Check if there are foreign objects around the inverter that affect heat dissipation, such as weeds. Remove foreign objects if any.<li data-bbox="725 1177 949 1366">4 Check the radiator fins of the inverter. Clean any dirt on the fins with a soft brush.	Once every six months to a year (depending on the dust content in the air)

No	Type	Details	Inspection Interval
6	Fan maintenance	<ol style="list-style-type: none"> 1 Use the iSolar-Cloud App to activate the fan self-test function and check for fan alarms. 2 Check if there are abnormal noises when the fan are operating. 3 If necessary, clean or replace the fan. 	Once a year
7	Temperature inspection	<ol style="list-style-type: none"> 1 Check the temperature at the AC wiring terminals. 2 Check the temperature at the DC wiring terminals. 3 Conduct thermal imaging studies. 	Once a year

No	Type	Details	Inspection Interval
8	Emergency stop function inspection	<ol style="list-style-type: none"> 1 Locate the emergency stop interface on the equipment. If the equipment has an external emergency stop switch, you can shut down the equipment directly using the emergency stop switch. 2 If the equipment lacks an external emergency stop switch, it can be shut down using an external conducting wire. If there is no emergency stop wired up, then the test shall be skipped. 	Once every six months to a year

4.2 Inspection Instructions

4.2.1 Check Installation Reliability

During routine or periodic maintenance, inspecting mounting bracket bolts is essential.

step 1 Prioritize checking for rust on the screws. If rust is present, replace the screws.

step 2 After confirming the screws are rust-free, use a torque wrench to tighten the mounting bracket bolts with the standard torque of 35N.m.

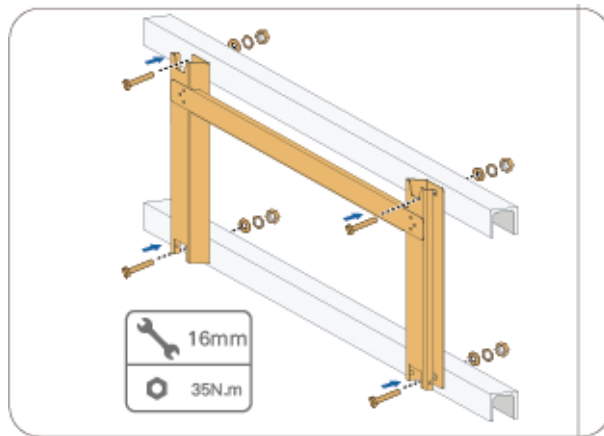

step 3 Upon completion, recheck to ensure the bolts are secure.

-- End

4.2.2 Check Product Labels and Signs

step 1 Carefully check if the warning labels on the equipment are clearly visible. If any labels are faded, blurred, or the text on them is illegible, contact Sungrow for a timely replacement.

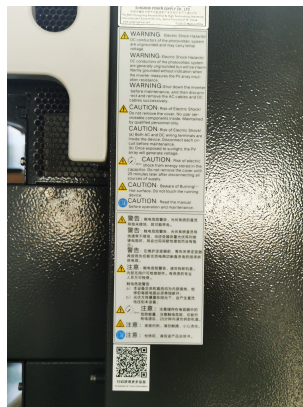

step 2 Carefully check if the nameplates on the equipment are clearly visible. If any nameplates are faded, blurred, or the text on them is illegible, they need to be replaced promptly.



-- End

4.2.3 Check DC Cables

Please conduct the following inspections for the DC cables:



Before performing the following operations, ensure that the inverter is powered off. Refer to Inverter Power-off for the detailed operation steps.

step 1 Check if the unused DC input terminals of the inverter are sealed with plugs. If not, use the blue plugs provided with the inverter to seal the terminals.

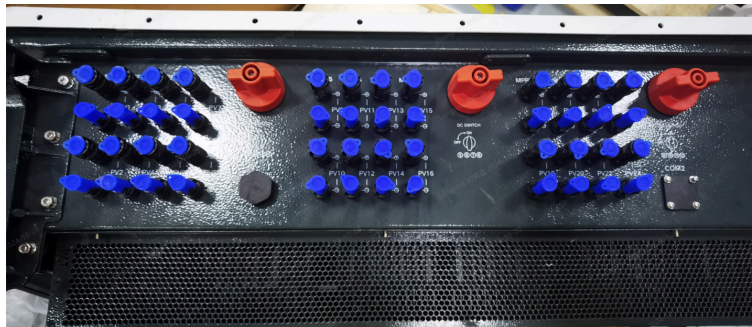

step 2 Check if the DC input terminals are deformed due to the tension of the DC cables. If this is the case, replace the cables and increase their length.

step 3 Please inspect the cables for damage, particularly the sections in contact with the metal enclosure. Besides on-site inspections, you can verify cable damage through iSolarCloud warning codes. Refer to Inspection of cable damage alarm for details. If any cable is damage is found, replace the cable promptly.

-- End

4.2.4 Check AC Cables

Please conduct the following inspections for the AC cables:



Before performing the following operations, ensure that the inverter is powered off. Refer to Inverter Power-off for the detailed operation steps.

step 1 Check if the grounding wire on the AC side is loose or detached. Tighten the fixing bolts with an M8 socket. If the grounding wire is loose or detached, re-crimp the OT terminal of the grounding wire.

WARNING

It is suggested that the external protective grounding terminal and the AC side grounding terminal are both connected to ground. Other grounding schemes, which meet the local standards and safety regulations, may also be adopted. However, SUNGROW shall not be held liable for any consequence caused thereby.

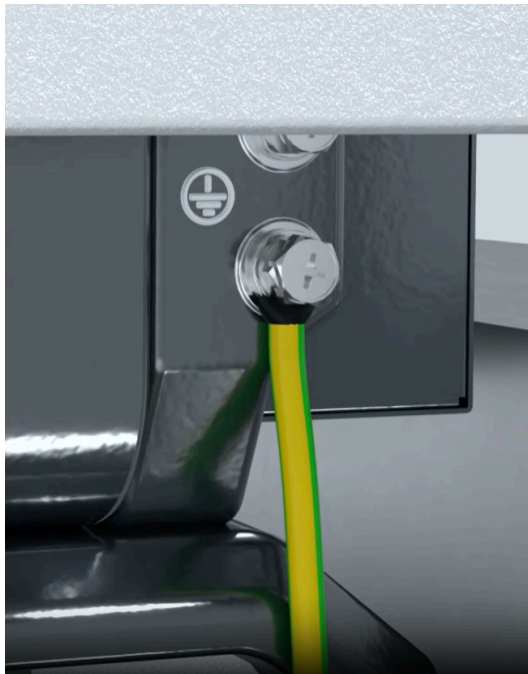

step 2 Check if the AC cable inlet is sealed properly. If necessary, reseal the cable inlet with fire-resistant clay. If the fire-resistant clay cracks later, remove the cracked clay and reseal the entry.



step 3 Check if the fixing bolts of the AC wiring terminals are loose. If any terminals are loose, use an M12 socket to tighten them with a torque of 20-30N.m after powering off.



step 4 Please inspect the cables for damage, particularly the sections in contact with the metal enclosure. In addition to on-site observations, you can identify cable damage according to iSolarCloud alarm codes. Refer to Inspection of cable damage alarm for details. If any cable is damage is found, replace the cable promptly.

-- End

4.2.5 Clean Air Outlets and Heat Sink Fins



Ensure the inverter is completely powered off before proceeding with the following operations. For detailed instructions, see [9.2 Disconnecting the Inverter](#)



Do not use cleaning agents to clean the inverter, as this may damage the inverter. Any damage resulting from failure to follow this instruction will not be covered by warranty.

step 1 Inspect the area around the inverter for any foreign objects, such as weeds, that may obstruct heat dissipation. If found, remove these objects in time.

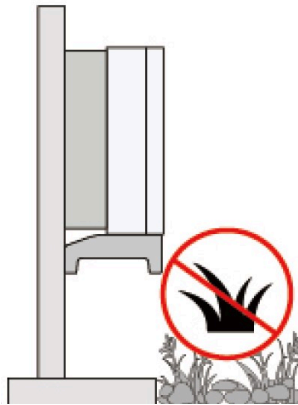

step 2 Inspect the inverter's heat sink fins for dust accumulation. If dust is present, follow the steps below to clean the fins.

- 1 Remove the 12 screws at the bottom of the rear cover using an electric drill.



- 2 Slide the rear cover horizontally to remove it and reveal the heat sink.



3 Gently clean the upper and lower fins with a soft brush.

-- End

4.2.6 Fan Maintenance

⚠ DANGER

- **Power off the inverter and disconnect it from all power supplies before maintaining fans.**
- **After the inverter is powered off for 25 minutes, measure the voltage and current with professional instrument. Only when there is no voltage nor current can operators who wear protective equipment operate and maintain the inverter.**
- **Fan maintenance must be performed by professionals.**

Fans inside the inverter are used to cool the inverter during operation. If the fans do not operate normally, the inverter may not be cooled down and inverter efficiency may decrease. Therefore, it is necessary to clean dirty fans and replace the broken fans in a timely manner.

The operation procedure is as follows:

step 1 Stop the inverter (see [9.2 Disconnecting the Inverter](#)).

step 2 Loosen the screw on the sealing plate of the fan module.

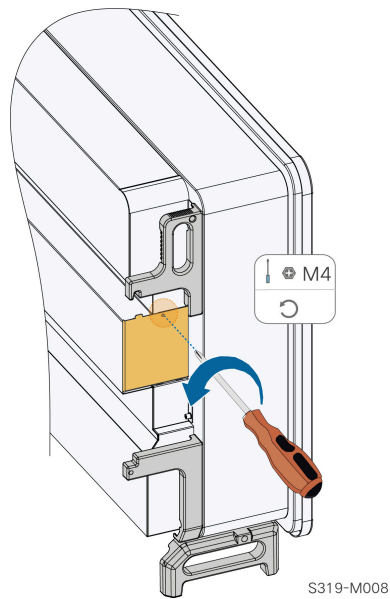

step 3 Press the tab of the latch hook, unplug the cable connection joint outwards, and loosen the screw on the fan holder.

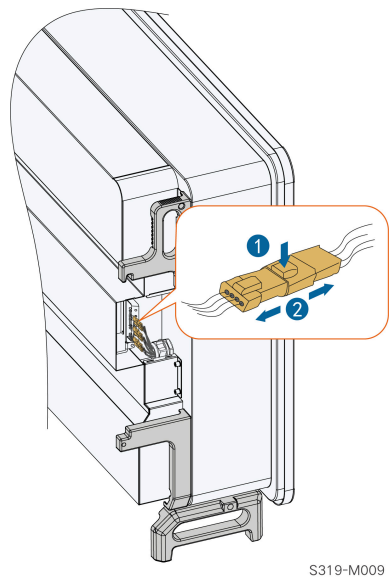

step 4 Loosen screws on the sides of fans.

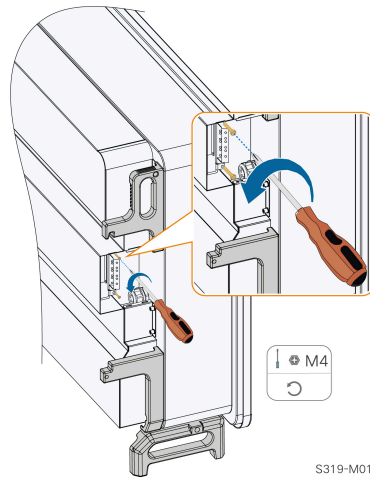

step 5 Pull out the fans. Clean them with a soft brush or vacuum cleaner, and replace them when necessary.

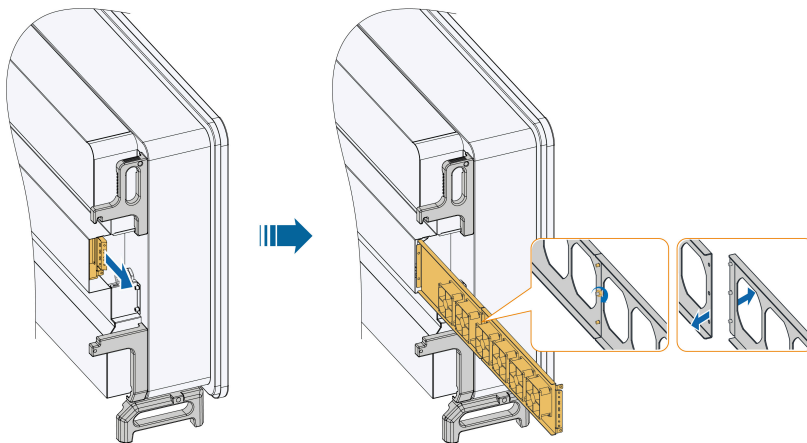

If there is not enough space, pull out part of the fans and remove the screws between the two fans.

-- End

4.2.7 Check Temperature



The thermal imaging inspection should be conducted with the power on. However, ensure the inverter is powered off when fastening bolts or crimping.

step 1 During inverter operation, use a thermal imager to check the temperature of the AC wiring terminals. If the temperature is abnormal, tighten the bolts and re-crimp the DT terminals after powering off.

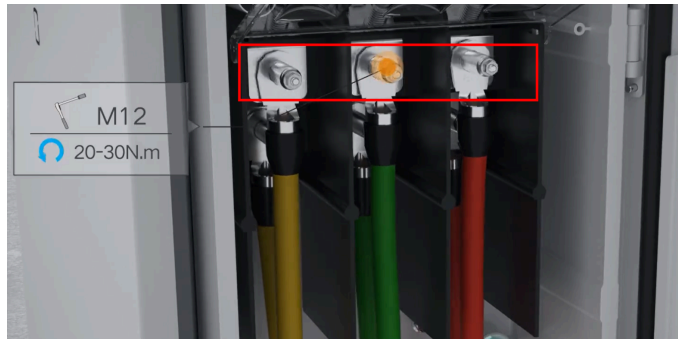

step 2 Use a thermal imager to scan the DC terminals. If the temperature is abnormal, replace the DC input terminals.

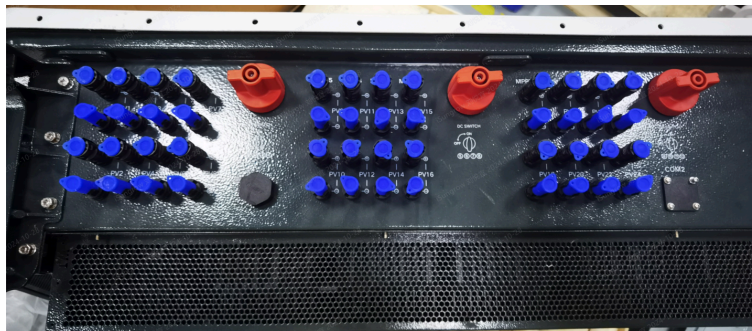

step 3 Determine the temperature of the target based on the infrared thermal image output from the thermal imager. Taking the figure below for example, different colors on the thermal image represent different temperatures of the target.

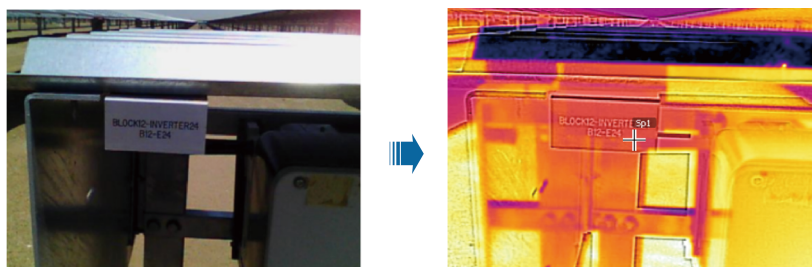

A thermal imager can determine the temperature of the target, provided the inverter output power reaches 80%.

-- End

4.2.8 Check Emergency Stop Function

Locate the emergency stop interface on the equipment. If the equipment has an external emergency stop switch, you can shut down the equipment directly using the emergency stop switch. After shutting down, re-verify the inverter's operating status through the iSolarCloud App. Refer to Home for the inverter operating status.

4.3 Inspection (via iSolarCloud or Logger)

4.3.1 Inspection Checklist

No	Type	Details	Inspection Interval
1	Fan alarm inspection	Use the iSolarCloud App to activate the fan self-test function and check for fan alarms.	Once a year
2	Firmware upgrade inspection	Check if the firmware versions of multiple inverters are consistent on the iSolarCloud web interface.	Once every six months to a year
3	Parameter setting inspection	Check if the parameter settings of multiple inverters are consistent on the iSolarCloud web interface.	Once every six months to a year
4	App time display inspection	Check if the time displayed on the iSolarCloud App is accurate.	Once a year

4.3.2 iSolarCloud App

4.3.2.1 Home

After login, the home page is as follows:

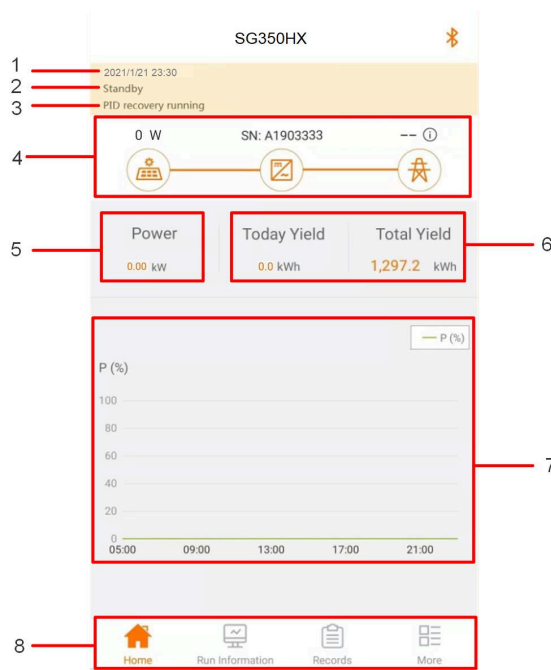

figure 4-1 Home Page

table 4-2 Home Page Description

No.	Designation	Description
1	Date and time	System date and time of the inverter
2	Inverter state	Present operation state of the inverter. For details, refer to table 4-3 Description of Inverter State .
3	PID function state	Present state of the PID function. For details, refer to table 4-4 Description of PID Function State
4	Power flow chart	Display the PV power generation power, feed-in power, etc. The line with an arrow indicates energy flow between connected devices, and the arrow pointing indicates energy flow direction.
5	Real-time power	Output power of the inverter
6	Power generation	Today power yield and accumulative power yield of the inverter
7	Power curve	Curve showing change of power between 5 am and 23 pm every day (Each point on the curve represents the percentage of present inverter power to rated power)
8	Navigation bar	Including Home , Run Information , Records , and More

table 4-3 Description of Inverter State

State	Description
Run	After being energized, inverter tracks the PV arrays' maximum power point (MPP) and converts the DC power into AC power. This is the normal operation mode.
Stop	Inverter is stopped.
Press to Shut Down	Inverter will stop operation by tapping "Stop" via app. In this way, inverter internal DSP stops. Restart the inverter via app if needed.
Standby	Inverter enters standby mode when DC side input is insufficient. In this mode inverter will wait within the standby duration.
Initial standby	The inverter is in the initial power-on standby state.
Starting up	The inverter is initializing and synchronizing with the grid.
Warn run	Warning information is detected.
Derating running	The inverter derates actively due to environmental factors such as temperature or altitude
Dispatch Running	The inverter runs according to the scheduling instructions received from the monitoring background
Shut down	If a fault occurs, inverter will automatically stop operation, the AC relay acts. The fault information will be displayed on the app. Once the fault is removed in recovery time, inverter will automatically resume running.

table 4-4 Description of PID Function State

State	Description
PID recovery running	The inverters perform PID recovery actively.
PID abnormality	It is detected that the ISO impedance is abnormal or the PID function cannot work normally after the PID function is enabled.

If the inverter is running abnormally, the alarm or fault icon  will be displayed in the lower right corner of the inverter icon in power flow chart. The user can tap this icon to enter the alarm or fault interface to view detailed information and corrective measures.

4.3.2.2 Records

Tap **Records** on the navigation bar to enter the interface showing event records, as shown in the following figure.



figure 4-2 Records

Fault Alarm Record

Tap **Fault Alarm Record** to enter the interface, as shown in the following figure.

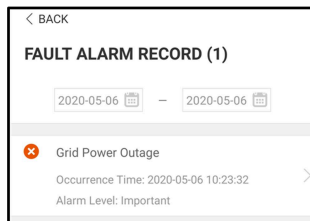



figure 4-3 Fault Alarm Record



Tap  to select a time segment and view corresponding records.
The inverter can record up to 400 latest entries.

Select one of the records in the list and tap the record to view the detailed fault information as shown in following figure.

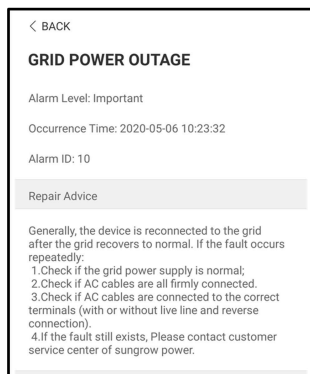



figure 4-4 Detailed Fault Alarm Information

Event Record

Tap **Event Record** to view event record list.



Tap  to select a time segment and view corresponding records.
The inverter can record up to 400 latest entries.

4.3.2.3 Login

step 1 Open the App to enter the login page, tap **Local Access** at the bottom of the page to go to the next page.

step 2 Establish the Bluetooth connection by either of the two following ways. If the LED indicator flashes blue, the connection is successfully established.

- Scan the QR code on the side of the inverter for Bluetooth connection.
- Tap "Manual connection" and select "Others" at the bottom of the page, the Bluetooth search page will automatically pop up, and select the inverter to be connected according to the SN on the nameplate on the side of the inverter body.

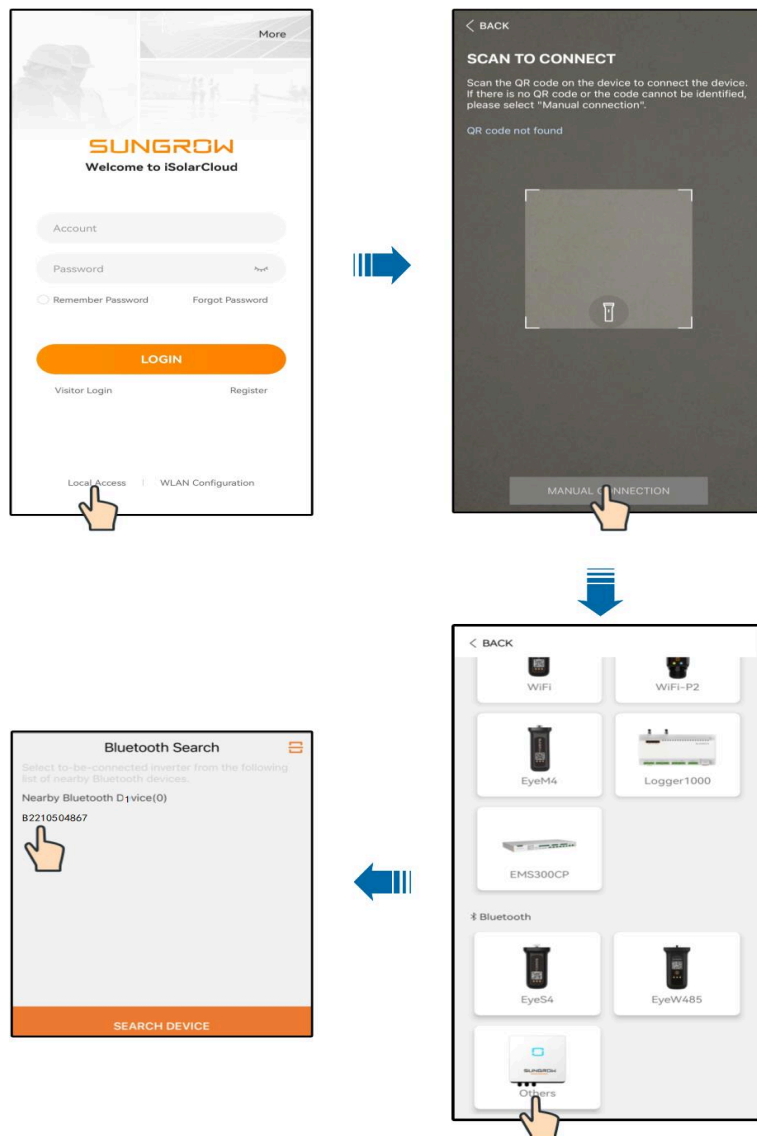

figure 4-5 Bluetooth Connection

step 3 Enter the identity verification interface after the Bluetooth connection is established.

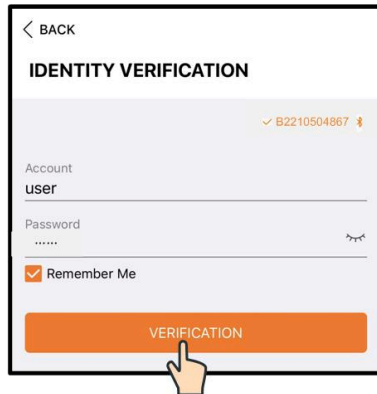

figure 4-6 Login



The Account is "user", and the initial password is "pw1111" or "111111" which should be changed for the consideration of account security. To set inverter parameters related to grid protection and grid support, contact your distributor to obtain the advanced account and corresponding password. If the distributor is unable to provide the required information, contact SUNGROW.

step 4 If the inverter is not initialized, you will enter the quick setting interface of initializing protection parameters.

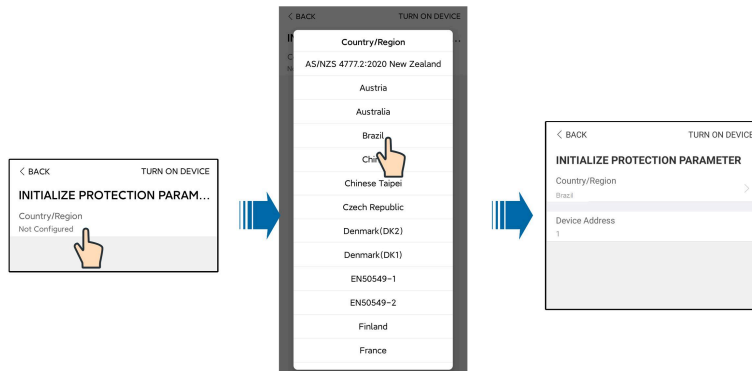

figure 4-7 Initialization Protection Parameter

NOTICE

The Country/Region must be set to the country where the inverter is installed. Otherwise, the inverter may report errors.

step 5 After finishing the settings, tap **TUNR ON DEVICE** at the upper right corner and the device will be initialized. The App will send start instructions and the device will start and operate.

step 6 If the inverter is initialized, the App automatically turns to its home page.

-- End

4.3.2.4 System Parameters

Tap **Settings > System Parameters** to enter the corresponding interface, as shown in the following figure.

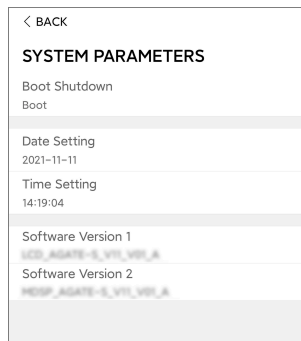

figure 4-8 System Parameters

* The image shown here is for reference only.

Boot/Shutdown

Tap **Boot/Shutdown** to send the boot/shutdown instruction to the inverter.

Date Setting/Time Setting

The correct system time is very important. Wrong system time will directly affect the data logging and power generation value. The clock is in 24-hour format.

Software Version

Version information of the current firmware.

4.3.2.5 App Time Display Check

This is to check if the system's current time is accurate and to set the system's current time and scheduled time synchronization for the inverter. If the system time is inconsistent, use the Logger4000's time synchronization function to synchronize the time with the inverter.



- To enable NTP, ensure the device's network environment is secure.
- It is recommended to first choose the IEC104 time synchronization method, followed by the iSolarCloud time synchronization method. Choose other time synchronization methods as needed.
- Only one clock source can be active at a time.
- It is necessary to configure the system time of the logger during its first use.

step 1 Click System -> System Time to enter the interface.

Inverter Timing

Current Time **2020-03-05 11:26**

Clock Source

User Define ▼

Use PC Time

Time Zone

(UTC+08:00) Beijing, Urum ▼

Date

2020-03-05

Time

11:26:32

Save

step 2 Check the option **Scheduled Time Synchronization with the Inverter** to synchronize the logger time with the inverter time.

step 3 In the drop-down box, select the corresponding clock source.

Clock source	Remarks
Manual time synchronization	<p>There are two ways to manually set the system's current time and time zone:</p> <ul style="list-style-type: none"> • Check the option "Synchronize Time with the Inverter" to synchronize the logger time with the inverter time. • Select the local time zone, date, and time, and click Save to manually set the logger time. <p>Manual time synchronization is recommended during commissioning.</p>
NTP	<p>This can synchronize the time of all devices in the network. Select the local time zone. Enter the domain name, set the time interval, and click Save. The logger will then synchronize with the server time.</p>
IEC104	<p>The prerequisite is that the logger communicates with the backend using the IEC104 protocol; otherwise, the clock source set to "IEC104" for time synchronization is invalid.</p>
iSolarCloud	<p>The prerequisite is that the logger is connected to the iSolarCloud platform; otherwise, the clock source set to "iSolarCloud" for time synchronization is invalid.</p>
MODBUS-TCP	<p>The prerequisite is that the logger communicates with the backend using the MODBUS-TCP protocol; otherwise, the clock source set to "MODBUS-TCP" for time synchronization is invalid.</p>
GPS	<p>In the time zone drop-down box, select the corresponding country and city, and click Save.</p>

-- End

4.3.2.6 Fan Alarm Inspection

step 1 Activate the fan self-test function on the iSolarCloud App and wait for 30s. After 30s, check the iSolarCloud App for fault codes. If fault code 70 appears, it indicates a fan problem. Refer to [4.3.2.2 Records](#) for alarm viewing steps.

step 2 Check the wiring and terminals related to the alarm codes for abnormalities, and inspect for foreign objects in the environment. Perform necessary repairs.

-- End

4.3.3 Check Firmware Version

Check that the inverters are all using the same firmware version through the **Logger4000 Web** system, or the **iSolarCloud Web** or **App (Local Access)**. In case of any inconsistency,

update the inverters to the same version by following the relevant instructions. In case of any questions, please contact Sungrow.

4.3.3.1 Firmware Version Check via iSolarCloud Web

Check that the inverters are all using the same firmware version through the iSolarCloud Web system. In case of any inconsistency, update the inverters to the same version by following the instructions.

step 1 Log in to the iSolarCloud Web system. Click on **Plant > Firmware Update** in the left-side menu.

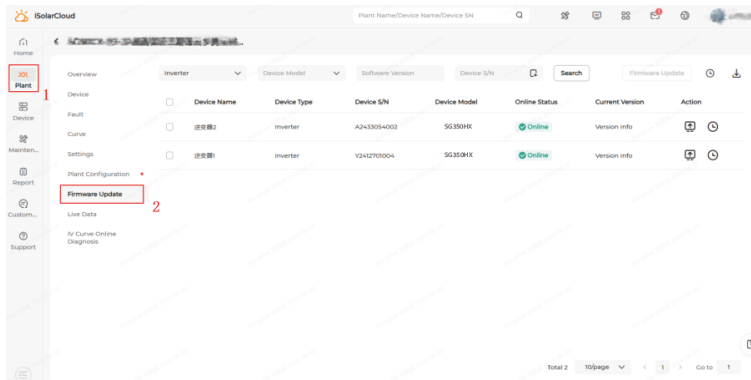

step 2 Click on the icon  on the right side to check if the inverter firmware versions of the plant are consistent.

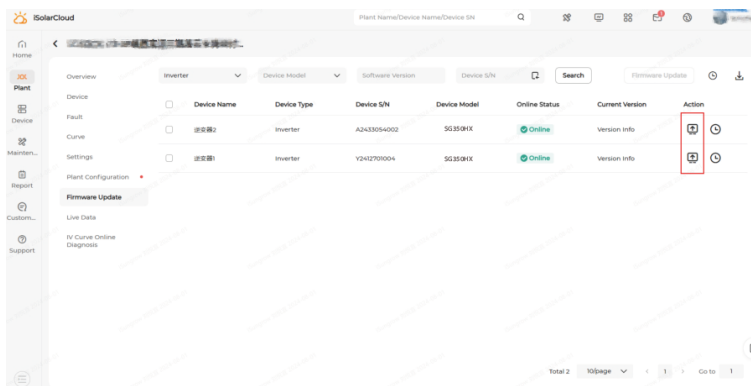

step 3 If the versions are inconsistent, refer to Firmware Update (Local Access) for synchronization.

-- End

4.3.3.2 Firmware Version Check via Logger

Check that the inverters are all using the same firmware version through the **Logger4000** Web system. In case of any inconsistency, update the inverters to the same version by following the instructions.

step 1 Log in to the **Logger4000** Web system, and choose **Device > Firmware Update** on the left.

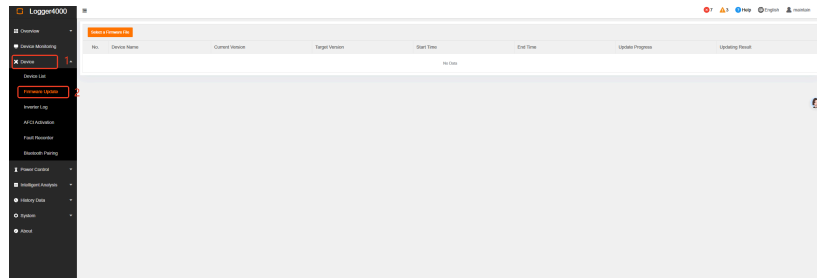

step 2 Click **Select a Firmware File** to choose an update package. Then, select all inverter devices, and click **Update** to update them to the same version.

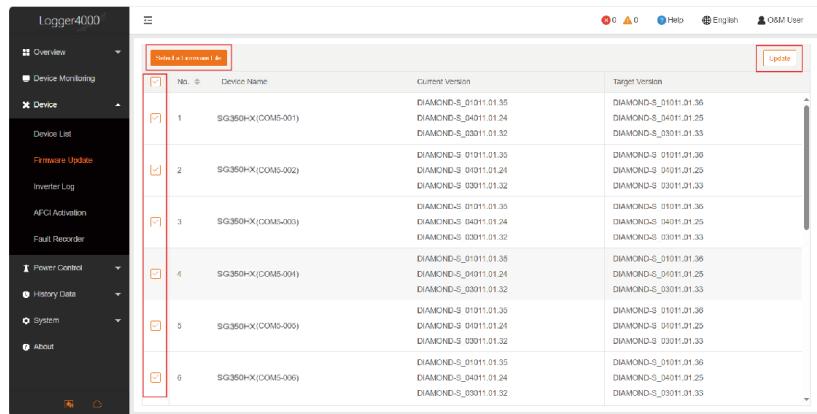

-- End

4.3.3.3 Firmware Update

To avoid download failure due to poor on-site network signal, it is recommended to download the firmware package to the mobile device in advance.

step 1 Enable the "Mobile data" of the mobile device.

step 2 Open the App, enter the account and password on the login interface. Tap **Login** to enter the home interface.

step 3 Tap **More > Firmware Download** to enter corresponding interface on which you can view the device list.

step 4 Select the device model before downloading the firmware. Tap the device name in the device list to enter the firmware upgrade package detail interface, and tap  behind the firmware upgrade package to download it.

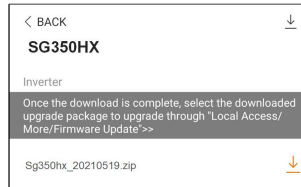

step 5 Return to the **Firmware Download** interface, tap  in the upper right corner of the interface to view the downloaded firmware upgrade package.

step 6 Login the App via local access mode. Refer to [Login](#).

step 7 Tap **More** on the App home interface and then tap **Firmware Update**.

step 8 Tap the upgrade package file, a prompt box will pop up asking whether to upgrade the firmware with the file, tap **CONFIRM** to perform the firmware upgrade.

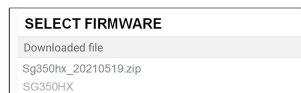

step 9 Wait for the file to be uploaded. When the upgrade is finished, a message is displayed indicating that the upgrade is completed. Tap **Complete** to end the upgrade.

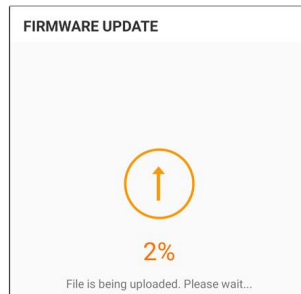

-- End

4.3.4 Check Parameter Settings

Check that the parameter settings of the on-site inverters are consistent, particularly, the protection and power parameters. When changing any parameter, ensure that the change is synchronized across all inverters and no one is left behind. You can update the settings using the **Logger4000 Web** system or the **iSolarCloud Web** system. In case of any questions, please contact Sungrow.

4.3.4.1 Parameter Setting via iSolarCloud Web

Below are the instructions for setting inverter parameters through the iSolarCloud Web system.

step 1 Log in to the iSolarCloud Web system. Click on **Device > Settings** in the left-side menu.

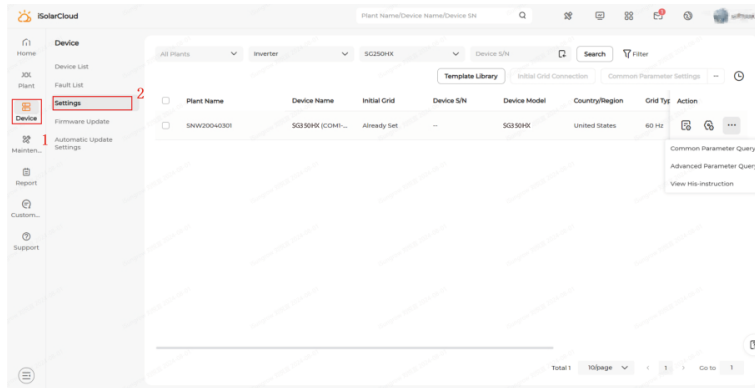

step 2 Choose **Device > Common Parameter Query**.

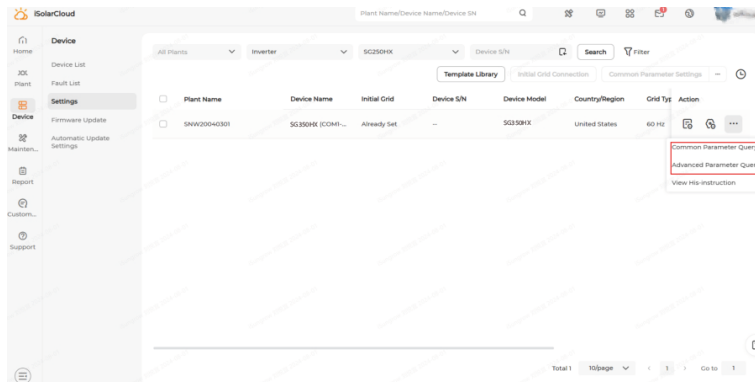

step 3 Adjust parameters according to the information bar.

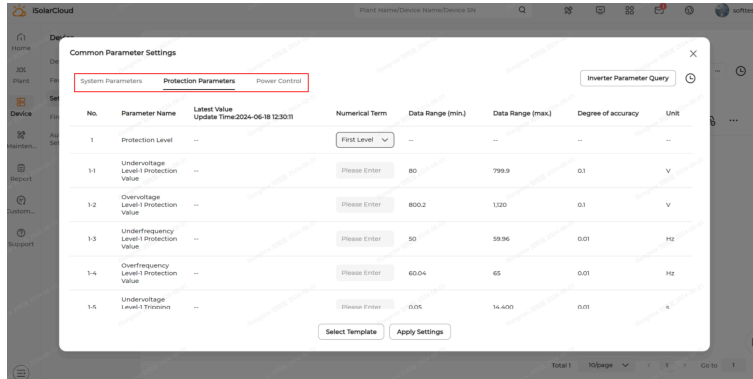

-- End

4.3.4.2 Parameter Setting via Logger

Below are the instructions for setting inverter parameters through the **Logger4000** Web system.

step 1 Log in to the **Logger4000** Web system, Choose **Device Monitoring > Power Regulation Parameters** in the upper tab bar to check or change the parameter settings.

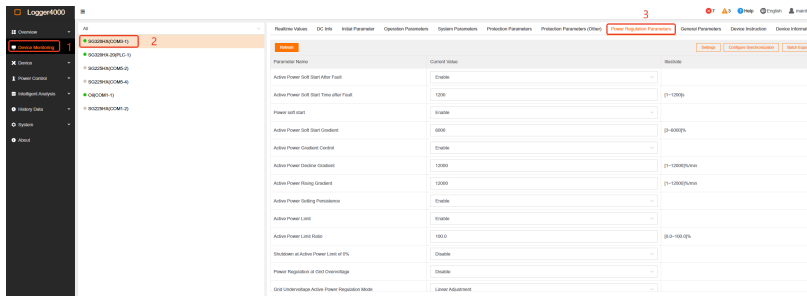

step 2 Choose **Device Monitoring > Protection Parameters** in the upper tab bar to check or change the parameter settings.

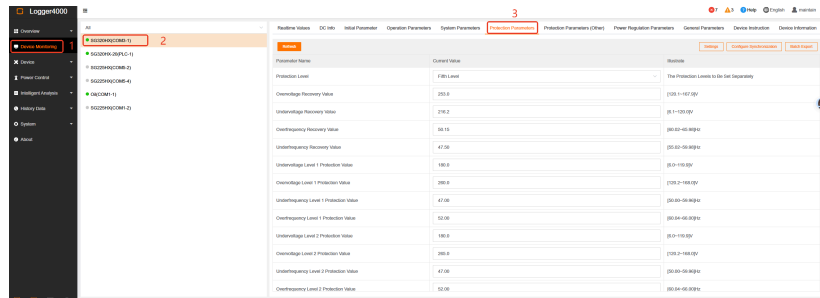

-- End

5 MVS Inspection

5.1 Inspection Checklist

The inspection checklist of the MV station is as follows.



- The recommended maintenance intervals provided below should be adjusted based on the specific environmental conditions where the product is installed.
- Factors such as the scale of the plant, installation location, and on-site environmental conditions will influence the maintenance intervals. If the operating environment is windy and sandy or contains heavy dust, it is necessary to shorten the maintenance intervals and increase the maintenance frequency.

S/N	Type	Details	Inspection interval
1	Check system status	<ol style="list-style-type: none">1 Check whether the interior and enclosure temperatures of the product are excessively high.2 Check whether the internal components and main circuits of the equipment are deformed or damaged.3 Check for condensation within the product.4 Check for any abnormal noises during the operation of the internal equipment.	Once a month
2	Check appearance	<ol style="list-style-type: none">1 Check the top and surrounding areas of the product for any flammable or explosive materials, installation tools, or miscellaneous items.2 Check whether the door locks and hinges of the product function normally.3 Check the sealing strips for proper sealing performance.	Once every six months

S/N	Type	Details	Inspection interval
			Once every six months
3	Check system cleanliness	<ol style="list-style-type: none"> 1 Remove dust from internal components of the MV station. 2 Check radiators for dust. 3 Check the top air inlet for dust. Remove dust promptly if necessary. 4 Check the bottom air outlet for dust. Remove dust promptly if necessary. 	 <p>If the power station is in other harsh environments such as sandstorms and wil-low catkins, please increase the frequency of inspections and cleaning according to the degree of dirt.</p>

5.2 Check System Status

step 1 Check whether the interior and enclosure temperatures of the product are excessively high.

- 1 Use a temperature measuring instrument to measure the temperatures of the interior and enclosure of the product, and record the temperatures.
- 2 Compare the measured temperatures with the specifications of each component, and replace any component with temperature exceeding the permissible range.

step 2 Check whether the internal components and main circuits of the equipment are deformed or damaged.

- 1 Open the MV station cabinet door.
- 2 Visually check the internal components and main circuits for damage or deformation.
- 3 If there is any damage or deformation , please get in touch with service specialist for judgement.

step 3 Check for condensation within the product.

- 1 Open the MV station cabinet door, check for condensation on the cabinet doors and PC sealing plates.
- 2 If condensation is present, check for damage to sealing strips of the doors, and air inlets and outlets.
- 3 Replace damaged sealing strips and air dry condensation.

step 4 Check for any abnormal noises during the operation of the internal equipment.

Determine whether the noises are caused by mechanical looseness or abnormal equipment vibration.

- Noises caused by mechanical looseness: Identify the loose parts and re-fasten the loose components.

-- End

5.3 Check Appearance

step 1 Check the top and surrounding areas of the product for any flammable or explosive materials, installation tools, or miscellaneous items.



Common flammable materials include but are not limited to linoleum, wood, paint, plastics, and decoration and fit-out materials.

- 1 Wear safety helmets, protective clothing and other protective gear, visually check if there are flammable and explosive materials around the all-in-one machine. If any, move the materials to another place away from the all-in-one machine.
- 2 Wear safety rope and other protective gear. Use a climbing ladder to check if there are flammable and explosive materials, tools or other debris on the top of the all-in-one machine. If any, move the items to another place away from the all-in-one machine.

step 2 Check whether the door locks and hinges of the product function normally.

- 1 Wear safety gloves. With the cabinet door lock locked or unlocked, check if the MV station door can be opened and closed manually.
- 2 Wear safety gloves, and open the LV cabinet doors. Open and close the doors repeatedly to check for any resistance or obstruction. If any abnormality is found, apply lubricating oil to the faulty door locks. If this does not resolve the issue, contact Sungrow for door replacement.
- 3 Visually check the screw cover plates of the MV station for any missing screws. If any screws are missing, contact Sungrow for new screws.
- 4 Use an appropriate wrench or screwdriver to check for loose screws. If any screws are loose, tighten them promptly.

- 5 Open side doors of the MV station, and utilize an electric screwdriver to detach screws from the side doors. Check whether the doors operate smoothly and whether they produce abnormal noises. If any doors exhibit stiffness or produce abnormal noises, apply lubricating oil to the hinges.

* The above pictures are for reference only. The received product may be different!

step 3 Check the sealing strips for proper sealing performance.

- 1 Open side doors of the MV station and check the outer rubber strips of the doors for problems such as damage, detachment, and breaks.
- 2 If any anomalies are detected, remove the defective rubber strips and replace them with new ones.

* The above pictures are for reference only. The received product may be different!

- - End

5.4 Check System Cleanliness

step 1 Remove dust from internal components of the MV station.

- 1 Open the cabinet door and remove the PC seal plate and sheet metal.
- 2 Check circuit boards, circuit breaker switches and other components for dust.
- 3 If dust is present, use a vacuum cleaner to remove the dust.

step 2 Check radiators for dust.

- 1 On the LCD screen, tap **Function > Run-information > INV Unit**.
- 2 Check if the temperatures of **PM1**, **PM3**, and **PM5** are above 96 °C.
- 3 If higher than 96 °C, unscrew the bolts around the MV station's side cabinet door equipped with radiators, and open the side door.
- 4 Open the MV station fan cover plate and check for dust on the radiator.
- 5 If dust is present, use a vacuum cleaner to remove the dust.

step 3 Check the top air inlet for dust. Remove dust promptly if necessary.

Steps for cleaning the bolt-fastened air inlet

- 1 Loosen the fastening bolts on the top air inlet and remove the cover plate.
- 2 Remove the filter mesh and filter sponge.
- 3 Use a vacuum cleaner to clean the filter sponge.

After cleaning, be sure to restore the filter mesh and filter sponge.

Steps for cleaning the elbow air inlet

- 1 Pull the two spring plungers of the air outlet inward.
- 2 Flip the filter sponge pressure plate along the fixed axis. Open the pressure plate and remove the filter sponge.
- 3 Use a vacuum cleaner to clean the filter sponge.

After cleaning, be sure to restore the filter sponge and pressure plate.

step 4 Check the bottom air outlet for dust. Remove dust promptly if necessary.

- 1 Loosen the fixing screws of the filter mesh and the MV station bottom, and remove the filter mesh.
- 2 Use a vacuum cleaner to clean the filter sponge.

After cleaning, be sure to restore the filter mesh, filter components, filter sponge, etc.

-- End

6 Transformer Inspection

6.1 Inspection Checklist

The inspection checklist of the transformer is as follows.



- The recommended maintenance intervals provided below should be adjusted based on the specific environmental conditions where the product is installed.
- Factors such as the scale of the plant, installation location, and on-site environmental conditions will influence the maintenance intervals. If the operating environment is windy and sandy or contains heavy dust, it is necessary to shorten the maintenance intervals and increase the maintenance frequency.

S/N	Type	Details	Inspection interval
1	Check the external condition of the transformer	<ol style="list-style-type: none"> 1 Check for oil leakage from the transformer. 2 Check the oil level gauge for normal operation. 3 Check whether the operating temperature is normal. 4 Check whether the operating noise is normal. 5 Check for external corrosion. 6 Check the main components of the transformer. 	Once a year
2	Cable connections	<ol style="list-style-type: none"> 1 Check electrical connections. 2 Check whether the transformer cover plate is tightly closed. 	Once a year

S/N	Type	Details	Inspection interval
3	Transformer protection status	<ol style="list-style-type: none"> 1 Check on the web interface to see if there are any fault alarms for the pressure relief valves, thermometers, gas relays and other devices. 2 Check whether the dial indications of pressure relief valves, thermometers, gas relays, and other devices are within normal ranges. 3 Check whether the liquid level gauge changes with the oil temperature. 	Once a year
4	Transformer node signal	Check whether power supply transformer alarms, tripping signals and other node signals are correct.	Once a year

6.2 Check the External Condition of the Transformer

The following inspection operations only require a visual assessment of the transformer and do not necessitate powering off the equipment.

WARNING

Ensure that the equipment is shut down before inspection!

step 1 Check for oil leakage from the transformer.

- 1 Check the area on the container where the transformer is installed for any presence of transformer oil. (Please distinguish between oil and water.)
- 2 If oil leakage is detected, focus on inspecting the oil leakage traces on the transformer's surface, and identify the leakage point based on these traces, such as: low-voltage connection cabinet, high-voltage connection chamber, bottom of radiating fins (by touch), oil level gauge, gas relay, pressure release valve, oil drain valve, sampling valve, windings, and oil level temperature controller, among others.
- 3 In case of oil leakage, promptly take photographs to document the oil leakage, and contact Sungrow.

step 2 Check the oil level gauge for normal operation.

- 1 Check if the pointer on the oil level gauge (as shown in A in the following figure) exceeds the upper or lower red lines on the dial.
- 2 Compare the oil level gauge with the thermometer (as shown in C in the following figure) and the oil level curve label (as shown in B in the following figure) on the transformer to check for any abnormal display on the oil level gauge. Examples of anomalies include

when the thermometer indicates a high temperature while the oil level gauge indicates a low level, or vice versa. Such anomalies may indicate potential risks.

- 3 In the event of any of the aforementioned anomalies, promptly take photographs for documentation purposes and inform Sungrow.

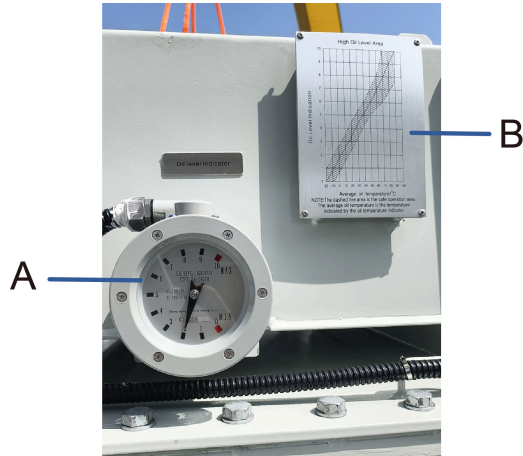

figure 6-1 Oil level gauge and oil level curve label



figure 6-2 Thermometer

step 3 Check whether the operating temperature is normal.

- 1 View the historical highest temperature and operating temperature of the temperature controller, and take photos for records. The historical highest temperature corresponds to the temperature indicated by the red pointer on the dial, while the operating temperature corresponds to the temperature indicated by the white pointer.



figure 6-3 Temperature controller

step 4 Check whether the operating noise is normal.

- 1 If the transformer emits a humming sound during operation, it is considered a normal operating sound.
- 2 If a sharp, piercing noise is emitted during operation, refer to the most recent oil sample DGA analysis of the transformer to check for any anomalies.

step 5 Check for external corrosion.

- 1 Check the radiating fins of the transformer, the surface of the oil tank and various accessories for visible rust or damage caused by rust.
- 2 If rust is present, take photos for records, remove the rust in time and take follow-up anti-corrosion measures. (For details, refer to the instructions in ISO 12944 standard.)



figure 6-4 Radiating fins

step 6 Check the main components of the transformer.

Consult the manufacturer's data of gas relays, pressure relief valves, thermometers and other components, and check whether the functions and maintenance of each component are normal. Pay particular attention to the fault judgment criteria of pressure release valves and other components, as well as the procedures for addressing anomalies.

-- End

6.3 Check Cable Connections

step 1 Check electrical connections.

- 1 Power down the transformer to stop its operation.
- 2 Open the terminal box of the transformer, check whether the connections of the XZ2 terminal block on the SCU and the XT1 terminal block of the transformer are intact.
- 3 Open the cabinet door of the high-voltage cable room in transformer. Check whether the cable connectors (as shown in Figure A below) are connected properly, whether there is any skew, whether the cable clamps (as shown in Figure B below) can securely clamp the cables (as shown in Figure C below), and whether the bolts are fastened without loosening.



figure 6-5 Cable compartment of the transformer

4 After inspection, close the cabinet doors.

step 2 Check whether the transformer cover plate is tightly closed.

- 1 Check whether the cover plate at the connection between the transformer and the MV station is tightly closed.
 - ① Visually check the cover plate for any missing screws. If any screws are missing, contact Sungrow promptly.
 - ② Use a wrench or screwdriver to check whether screws for looseness. If any screws are loose, tighten them promptly.
- 2 Check whether the cover plate on the transformer is tightly closed, using the same method as above.

-- End

6.4 Check the Transformer Protection Status

step 1 Check on the web interface to see if there are any fault alarms for the pressure relief valves, thermometers, gas relays and other devices.

step 2 Check whether the dial indications of pressure relief valves, thermometers, gas relays, and other devices are within normal ranges.

step 3 Check whether the liquid level gauge changes with the oil temperature.

-- End

7 Ring Main Unit Inspection

7.1 Inspection Checklist

The inspection checklist of the ring main unit is as follows.



- The recommended maintenance intervals provided below should be adjusted based on the specific environmental conditions where the product is installed.
- Factors such as the scale of the plant, installation location, and on-site environmental conditions will influence the maintenance intervals. If the operating environment is windy and sandy or contains heavy dust, it is necessary to shorten the maintenance intervals and increase the maintenance frequency.

S/N	Type	Details	Inspection interval
1	Check Cleanliness	Check the inside of the ring main unit for dust.	Once a year
2	Check Cable-Connections	<ol style="list-style-type: none"> 1 Check electrical connections. 2 Check the grounding connections. 	Once a year
		System status view:	
3	Check Switch Function	<ol style="list-style-type: none"> 1 Check whether the AC-side circuit breaker of the MV station can be turned off. 2 Check whether the circuit breaker of the ring main unit can be turned off. 3 Check whether the disconnecting switch of the ring main unit can be turned off. 4 Check whether the grounding switch of the ring main unit can be turned off. 	Once a year
4	Check Relay Protection Function (Optional)	Check whether protective relays function normally.	Once a year

7.2 Check Cleanliness

Check the inside of the ring main unit for dust.

- 2 Power off the CBU to ensure that the ring main unit is not electrified.
- 3 Open the door of the ring main unit and visually check the interior and bottom plate for dust.
- 4 If there is dust, use a brush, a dry duster and other tools to remove the internal dust.
- 5 If there is dust, use a broom to remove the dust on the internal bottom plate.



7.3 Check Cable Connections

step 1 Check electrical connections.

- 1 Power down the MV station to stop its operation.
- 2 Open the door of the high voltage chamber. The inside of the ring main unit is shown in the figure below. Observe the SF6 gas pressure in the ring main unit and check whether the pointer of the SF6 gas pressure gauge points to the green area.
- 3 Use the operating handle to disconnect the circuit breaker of the ring main unit, turn off the disconnecting switch, and set the grounding switch to the grounding position (at ○).

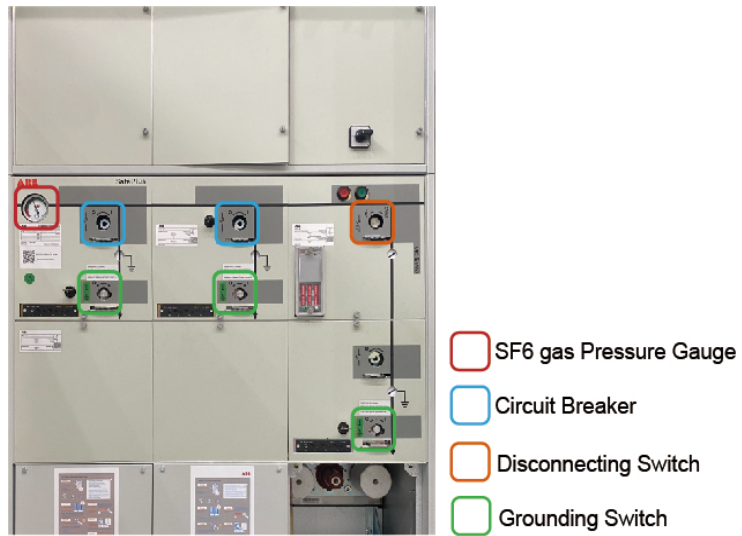

figure 7-1 RMU

- 4 Open the low-voltage box on the top of the ring main unit.
 - ① Check the backs of the protective relays for any loose or dropped wires.
 - ② Check whether the connections of the XZ3 terminal block on the SCU and the XSG terminal block of the ring main unit are correct according to the line marks. For any loose or dropped wires, promptly tighten the connections with tools.



figure 7-2 SCU terminal block



figure 7-3 XSG terminal block

- 5 Open the cabinet door of the high-voltage cable room in the ring main unit. Check whether the cable connectors (as shown in Figure A below) are connected properly, whether there is any skew, whether the cable clamps (as shown in Figure B below) can securely clamp the cables (as shown in Figure C below), and whether the bolts are fastened without loosening.



figure 7-4 Cable compartment of the ring main unit

- 6 If the equipment contains a CT, check whether the connections at both ends of the CT are secure and whether the cable lugs are intact. Tighten any loose connections promptly.



- 7 After inspection, close the cabinet doors.

step 2 Check the grounding connections.

- 1 Use the appropriate wrench or screwdriver to check for loosening of the grounding cable fixing screws. Tighten any loose screws promptly.
- 2 Gently pull the grounding cables to check whether the cable lugs are secure.

- 3 Check whether the shielding layer and the semiconductor layer are grounded reliably.



figure 7-5 Grounding of the shielding layer and the semiconductor layer

-- End

7.4 Check Switch Function

Check whether the grounding switch and load switch of the ring main unit function normally. While the transformer and ring main unit are powered off:

step 1 Check whether the AC-side circuit breaker of the MV station can be turned off.

step 2 Check whether the circuit breaker of the ring main unit can be turned off.

step 3 Check whether the disconnecting switch of the ring main unit can be turned off.

step 4 Check whether the grounding switch of the ring main unit can be turned off.

Please refer to [figure 7-1 RMU](#) for specific switch positions

-- End

7.5 Check Relay Protection Function (Optional)

Check whether protective relays function normally.

The main page of the protective relays displays information such as operating voltage, check whether the real-time data displayed by protective relays is normal.

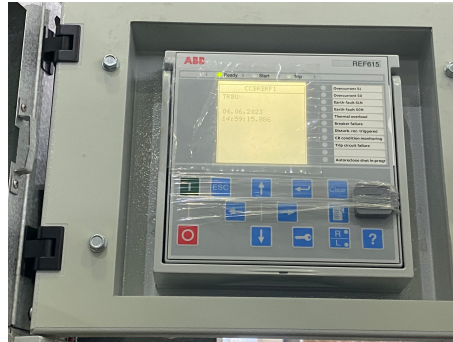

Before delivery, the protective relays were verified according to the commissioning instructions.

8 Foundation Inspection

8.1 Check the Foundation Structure

step 1 Visually check for significant gaps or any tilting of the foundation.

step 2 Visually check the paint condition of the foundation concrete structure. Touch up damaged areas if any.

step 3 Visually check for water seepage in the foundation concrete structure. If water seepage is observed, apply immediate waterproofing measures to the foundation.

step 4 Use instruments such as a level gauge to determine whether the foundation surface is tilted.

step 5 Visually inspect the bottom and surroundings of the foundation for any debris, and promptly clean up any debris.

-- End

8.2 Check Product Fixation

Check whether the product is firmly fixed to the foundation.

step 1 Use a torque wrench to measure and verify whether the bolt torque at foundation connections is within the permissible limits specified in the specifications. If any discrepancies are found, re-tighten the bolts according to the torque range specified in the manual.

step 2 Visually observe or use tools such as a hammer to lightly tap the embedded expansion bolts or chemical bolts to determine if they are loose. If looseness is found, contact the SUNGROW.

step 3 Use the angle ruler to check whether L-shaped steel is installed horizontally. If any L-shaped steel is installed incorrectly, reinstall it.



step 4 Check whether the embedded channel steel of the foundation is securely soldered to the container. If any soldering joints are insecure, repair soldering and apply anti-corrosion treatment afterward.



-- End

9 Appendixes

9.1 Inverter Power-on

9.1.1 Inspection Before Power-on

Check the following items before starting the inverter:

- All equipment has been reliably installed.
- DC switch(es) and AC circuit breaker are in the "OFF" position.
- The ground cable is properly and reliably connected.
- The AC cable is properly and reliably connected.
- The DC cable is properly and reliably connected.
- The communication cable is properly and reliably connected.
- The vacant terminals are sealed.
- No foreign items, such as tools, are left on the top of the machine or in the junction box (if there is).
- The AC circuit breaker is selected in accordance with the requirements of this manual and local standards.
- All warning signs & labels are intact and legible.

9.1.2 Power-on Steps

If all the above items meet the requirements, follow the steps below to start the inverter for the first time.

step 1 Turn on the AC circuit breaker between the inverter and the grid.

step 2 Turn the DC switch on the inverter to "ON," and the inverter indicator light will turn blue and flicker slowly.

step 3 Install the iSolarCloud App.

step 4 For the initial grid connection of the inverter, use the iSolarCloud App to initialize the protection parameter settings (see step 4 of [4.3.2.3 Login](#)). Under normal light and grid connection conditions, the inverter will operate normally.

step 5 After initialization, the App will automatically enter the home page. The inverter indicator light will stay blue, indicating the inverter is in grid-connected operation status.

-- End

9.2 Disconnecting the Inverter

CAUTION

Danger of burns!

Even if the inverter is shut down, it may still be hot and cause burns. Wear protective gloves before operating the inverter after it cools down.

For maintenance or other service work, the inverter must be switched off. Proceed as follows to disconnect the inverter. Lethal voltages or damage to the inverter will follow if otherwise.

- step 1** Disconnect the external AC circuit breaker and prevent it from inadvertent reconnection.
- step 2** Rotate the DC switch to the "OFF" position for disconnecting all of the PV string inputs.
- step 3** Wait about 25 minutes until the capacitors inside the inverter completely discharge.
- step 4** Ensure that the DC cable is current-free with a current clamp.

-- End

SUNGROW

Sungrow Power Supply Co., Ltd.
www.sungrowpower.com