



# **Manual for Photovoltaic Components Installation**



**青海黄河上游水电开发有限责任公司西宁太阳能电力分公司**  
**QingHai Huanghe Hydropower Development CO., Ltd. Xining Solar**  
**Power Branch**



## Important Safety Instructions

This installation manual contains installation and safe handling information of photovoltaic power generation modules (hereafter referred to as “modules”) of QingHai Huanghe Hydropower Development CO., Ltd. Xining Solar Power Branch (hereafter referred to HHDC as Solar Power). In modules installation and daily maintenance, you shall abide by all safety precautions and the relevant laws and regulations in the manual.

Installing module system needs professional skill and technology, and the installation can only be processed by the qualified persons. Please read this installation manual carefully. The installation person should be familiar with requirements of mechanical and electrical of the system. Please keep this manual properly for care and maintenance.

## Contents

1. Introduction.....	- 1 -
2. Rules and Regulations.....	- 1 -
3. General information.....	- 2 -
3.1 Module information.....	- 2 -
3.2 Normal safety.....	- 3 -
3.3 Electrical performance safety.....	- 3 -
3.4 Operational safety.....	- 4 -
3.5 Fire safety.....	- 5 -
4. Installation conditions.....	- 5 -
4.1 Installation sites and work environments.....	- 5 -
4.2 The choices of Inclination Angle.....	- 6 -
5. Unpacking and Handling Instructions.....	- 7 -
6. Machinery Installation.....	- 8 -
6.1 Normal requirements.....	- 8 -
6.2 Installation modes.....	- 9 -
7. Electrical installation.....	- 12 -
7.1 Electrical performance.....	- 12 -
7.2 Cable and wires.....	- 14 -
7.3 Connectors.....	- 14 -
7.4 Bypass diodes.....	- 15 -
8. Grounding.....	- 15 -
9. Operation and Maintenance.....	- 16 -
9.1 Clean.....	- 16 -
9.2 Appearance inspection for modules.....	- 17 -
9.3 Inspection for connectors and cables.....	- 17 -
10. Appendix.....	- 17 -
10.1 Mono-N-IBC module Electrical Characteristics.....	- 17 -



# 1. Introduction

Thank you for choosing HHDC Solar Power modules

This installation manual contains important electrical and mechanical installation information. Please understand the information firstly before installing modules. Furthermore, the manual also contains other safety information that you must know well.

The installation manual does not a warranty book, whether express or implied. It does not regulate any damage, modules damage or other compensation schemes arising of or related to the installation of modules, operation, use or maintenance. In case of the violations of the patent right or the right of the third party caused by using the modules, HHDC Solar Power does not undertake any liabilities. HHDC Solar Power reserves the right to change the product manual and the installation manual without any previous notice.

Clients install the modules not according to the requirements stipulated in the manual, shall result in the quality guarantee of products provided to clients in sales becoming invalid. Meanwhile, the suggestions in the manual have passed the tests and inspections in practice, in order to improve the safety in the process of installation. Please provide the owners of photovoltaic system with the manual for their references, and inform them all requirements and recommendations for safety, operation, and maintenance.

## 2. Rules and Regulations

Machinery installation and electrical installation of modules shall refer to applicable rules and regulations, including electrical rules, building law and power connection requirements. These regulations vary along with the installation places, such as building roof installation, automotive applications, etc. and the requirements may vary along with different installation system voltage, DC or AC.



### 3. General information

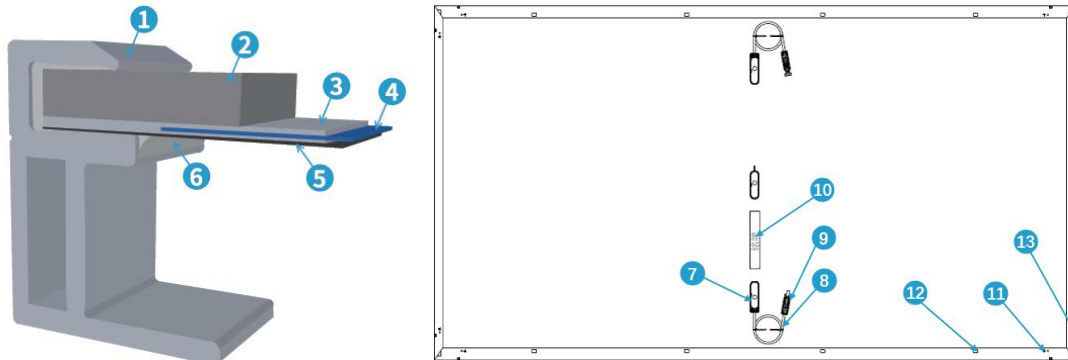

Diagram 1 Modules profile structure and parts instruction

①Aluminium alloy frame	②Glass	③Packaging POE	④Photovoltaic battery	⑤Backsheet
⑥Silica gel	⑦Connecting box	⑧Cable conductor	⑨Connector	⑩Nameplate
⑪Grounding hole	⑫Installing hole	⑬Drain hole		

#### 3.1 Module information

3 kinds of labels pasted on each module, which offer the following information:

1. Nameplate: describe product types, and standard rated power, rated current, rated voltage, open circuit voltage, short circuit current, certification mark, maximum system voltage and other information under the testing conditions.
2. Current classified label: classify the modules according to the optimum operating current value of modules, then according to the classified result, paste “X” label on the module, in which X has three values: H, M or L (respectively stand for "high current grade", "middle current grade" or "low current grade". The optimal operation in installation is install the modules pasted same “X” labels (e.g. all are H) in the same subarray.
3. Serial number: every module has an exclusive serial number. Every serial number consists of 14 letters and figures. For example: “XX-210702XXXXXX” stands for the production date of modules is July 2, 2021, and it will be permanently solidified inside the modules, you can see it clearly from the front and top of modules.



## 3.2 Normal safety

1. It needs to consider the entire fire rating when the modules are installed on the rooftop. Meanwhile, it also needs to consider the latter entire maintenance. Photovoltaic system on the rooftop only can be installed the places that are passed construction specialists or engineers' assessment with formal and analysis result for complete structure, and has been certified can bear additional system support pressure, including the weight of photovoltaic module itself.
2. For your safety, please do not work on the rooftop under the conditions without safeguard procedures, which include but are not limited fall-protection, and protective equipments for ladders or stairs and personal.
3. For your safety, please do not install or deal with modules under the adverse conditions, which include but are not limited strong wind or gust, wet rooftop or roof with sands.

## 3.3 Electrical performance safety

1. Photovoltaic products will generate direct current under the lighting condition, so touch connecting line metal of the modules will be in the risk of electrical shock or burns. 30 volt DC voltage or greater voltage may be deadly.
2. Modules will also generate voltage without connecting load or external circuit. Operate the module under sunshine, please use insulating tool and wear rubber gloves at the same time.
3. The photovoltaic modules do not equipped with switches. Only move photovoltaic modules away from lighting or use cloth, cardboard, or materials which are completely light-proof to keep out, or place the front of modules on the smooth and flat surface that the modules can stop running.
4. In order to avoid electric arc and electric shock risks, please do not break electrical connection under the condition with load. False connection also can result in electric arc and electric shock. Must keep connector dry and clean, ensure them in a good status. Do not insert other metal objects into connectors, or process electrical connection in other methods.
5. Snow and water in the surrounding environment will increase light intensity by reflecting, cause the increase of current and output power. Furthermore, voltage and



power of modules at low temperature will magnify accordingly.

6. If the glass of modules or encapsulating material has damage, please wear personnel safeguard equipment, separate modules from circuits.

7. Operation only can be done under the dry condition, and only can use dry instruments. When the modules are humid, do not operate the modules, unless wear appropriate electric shock protection equipment; operate according to the requirements of cleaning modules in the manual while cleaning modules.

### **3.4 Operational safety**

1. Do not open the outer packing in the progress of transport and store of modules unless the modules have reached the installation place.

2. Please protect the packing from damage. Forbid the packaged modules from directly falling.

3. Do not exceed the highest plies limitation marked on the packing container while piling up the modules.

4. Place the packing containers in ventilation, raining-proof and dry places before opening the packing containers.

5. Forbid lifting the whole module through grasping electrical connectors or cables in any cases.

6. Forbid standing or walking on the modules.

7. Forbid a piece of module from dropping on another module.

8. Do not put any heavy objects on the module glass, so as to avoid the damage of the glass.

9. Be careful when put a module in a plane, especially in the places with corners.

10. Do not try to disassemble the modules; do not remove the nameplates or parts on the modules.

11. Do not paint on the surface of modules or paint any other adhesives.

12. Avoid the back membranes of modules from damage, do not grasp or scratch the back membranes of modules.

13. Forbid drilling holes on frames of modules, which may reduce loading capacity of the frames and result in corrosion to the frames.

14. Do not scratch anodic oxidation layer on the surface of the aluminum alloy frame, except when grounding connection. Scratches may result in border corrosion to affect frame load capacity.





15. Forbid repairing the damaged glass or modules with damaged back membrane voluntarily.

### **3.5 Fire safety**

1. Please consult the local laws and regulations before installing the modules, abide by the requirements related to the fire safety of the buildings.
2. A layer of applicable fire-proof material must be covered on the rooftop when installing on the rooftop, and ensure adequate ventilation between the backboard and fitting surface.
3. Different rooftop structures and different installation modes may affect fire-proof safety performances of buildings. In case of improper installation, may lead to a fire disaster.
4. Please use proper modules accessories such as fuses, circuit breakers, grounding connectors according to the local rules and regulations.
5. Do not use modules in case of having exposed combustible gases nearby.

## **4. Installation conditions**

### **4.1 Installation sites and work environments**

1. Do not use a mirror surface or a magnifying glass to manually focus sunlight onto the modules. Artificially concentrated sunlight shall not be directed on the module or panel.
2. The modules must be installed in a suitable construction, or other places suitable to install modules (such as ground, garages, building outer walls, roofs, photovoltaic tracking systems).
3. Do not install the modules in the place that may be flooded.
4. Recommend modules should be installed in the work environment temperatures at  $-20\text{ }^{\circ}\text{C}$  to  $46\text{ }^{\circ}\text{C}$ , the work environment temperature is the monthly average temperature between the maximum temperature and the minimum temperature at the installation location. Module limitation work environment temperatures are  $-40\text{ }^{\circ}\text{C}$  to  $85\text{ }^{\circ}\text{C}$ . The module is applied to the area below 2000 meters above sea level.
5. Ensure the pressure from wind or snow shall not exceed the maximum allowable





load after the modules installed.

6. The modules shall be installed in the places that all the year round without shadow. Ensure the installation places for modules do not have obstacles that may block the light.
7. If the modules are installed in the places that thunder and lightning activated frequently, there must adopt measures to protect the modules from lightning stroke.
8. Do not install modules in the places where may have combustible gas around.
9. The modules cannot be installed and used in the conditions with excessive hail, snow, sand, dust, air pollution, soot, etc. The modules cannot be installed in places with strong corrosive substances such as salt, salt spray, salt water, active chemical vapor, acid rain, or any other materials that may corrode the modules, affect safety or performances of the modules.
10. Do not install modules in the places where More than 2000 m above sea level.

## 4.2 The choices of Inclination Angle



Inclination angle of the modules: an included angle formed by the surface of a module with horizontal plane. When the module directly faces to sunlight, the module will achieve the maximum power output.

1. The modules to be installed on the Northern Hemisphere are better to face south. The modules to be installed on the Southern Hemisphere are better to face north.
2. For the detailed installation angle, the modules can be installed fixedly, and also can adjust the angle between the module and the ground according to the changes of seasons, so as to make the modules accept more sunshine. The normal adjustment angles: (1) the acceptance angle is the local latitude  $-11^{\circ}48'$  after the spring equinox; (2) the acceptance angle is the local latitude  $+11^{\circ}48'$  after the autumnal equinox; (3) the annual average acceptance angle is  $+5^{\circ}$  of the local latitude; or can refer to the suggestions given by the experienced photovoltaic module installers.
3. If dusts fall on the surface of the modules, it will affect the power output performance of the modules. It is recommended that the installation included angle not less than  $10^{\circ}$  when installing the modules; thus, the dusts on the modules are easy to be taken away when raining.

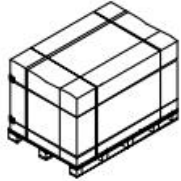

## 5. Unpacking and Handling Instructions

1. When unpacking please follow the recommended steps for unpacking, see outer box unpacking instructions, as follows:

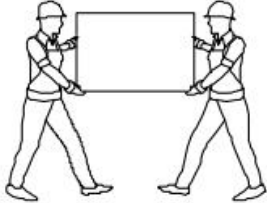
	<b>拆箱说明/Instructions for unpacking :</b>
<b>Step 1</b>	<b>步骤1/Step 1 :</b> 用美工刀或剪刀将箱体外塑钢带打开, 并去除薄膜 Use a box cutter or scissors to open the outer plastic tape and remove the film
	<b>步骤2/Step 2 :</b> 将箱体垂直抬起, 放置一旁 Lift the box vertically and set it aside
<b>Step 2</b>	
	<b>步骤3/Step 3 :</b> 将整托组件放置到距离固定物10cm的距离, 用美工刀或剪刀将内置塑钢带打开, 将组件斜靠至固定物 Place the unit 10cm from the fixture and open the inner plastic strip with a box cutter or scissors, recline the unit to the fixture
<b>Step 3</b>	
	<b>步骤4/Step 4 :</b> 抬组件需要2人操作, 且必须佩戴手套 Module should be handled by 2 persons, and must wear gloves
<b>Step 4</b>	

2. After opening the outer box remove the gloves placed inside and put them on for handling.



3. Do not touch the glass surface with your bare fingers during handling to avoid leaving fingerprints on the glass surface.

## 6. Machinery Installation

### 6.1 Normal requirements

1. Ensure the modules installation modes and support systems are solid enough to make the modules bear all scheduled loading conditions, which is the guarantee must be provided by support installers. Supports to be installed must pass the inspection and test processed by the third party accredited testing organization with static mechanics analysis ability.
2. Module installation supports must be made from the durable, corrosion resistant, and ultraviolet-proof materials.
3. The modules must be fixed on the installation support solidly.
4. In the area with larger snows in winter, choose higher installation supports. Thus, the lowest point of the module will not be covered by snows for a long time. Furthermore, the lowest point of the module is high enough that can avoid the modules are sheltered from plants and trees, or damaged by sand wind.
5. When the modules are installed on the supports that are parallel to the rooftops or walls, the minimum gap between module frames and rooftops or walls is 10cm, so as to circulate the air to protect the circles of the modules from damage.
6. Forbid punching holes on the glass and frames of the modules.



7. Before installing the modules on the rooftops, please ensure the buildings are suitable to install. Furthermore, any infiltration on the rooftop shall be sealed to prevent the leakage.
8. Modules frames will have expansion and contraction effect, so it is recommended that the minimum distance between the two modules is 1 cm.
9. Ensure the backboards of the modules cannot touch the supports or building structures inside the modules, especially when the surfaces of the modules under an external pressure.
10. The approved maximum static load of the modules: 3600Pa. Safety factor is 1.5.
11. The installation modes cannot lead to electrochemical corrosion between aluminum frames of modules and different kinds of metals.
12. The installation direction of the modules can be installed horizontally, also can be installed vertically.
13. For roof mounting applications the assembly is to be mounted over the fire resistant roof covering rated for the application.
14. The modules are equipped with PV wiring connectors that comply with the Standard for Connectors for Use in Photovoltaic Systems, UL 6703, different model connectors couldn't be mated with each other.
15. Where common grounding hardware (nuts, bolts, star washers, spilt-ring lock washers, flat washers and the like) is used to attach a listed grounding/bonding device, the attachment must be made in conformance with the grounding device manufacturer's instructions.

## 6.2 Installation modes

Modules can be installed to the racks by clamps or hooks. Modules must be installed according to the following examples and recommendation. If not mounting the Modules according to these instructions, please in advance consult HHDC Solar Power and must be approved by HHDC Solar Power, otherwise may damage Modules and void the warranty.

### 1. Install modules through the installing holes

Install modules through the installing holes in the frames of the back modules; use bolts to fix the modules on the supports; the installation details are as shown in

Diagram 2.

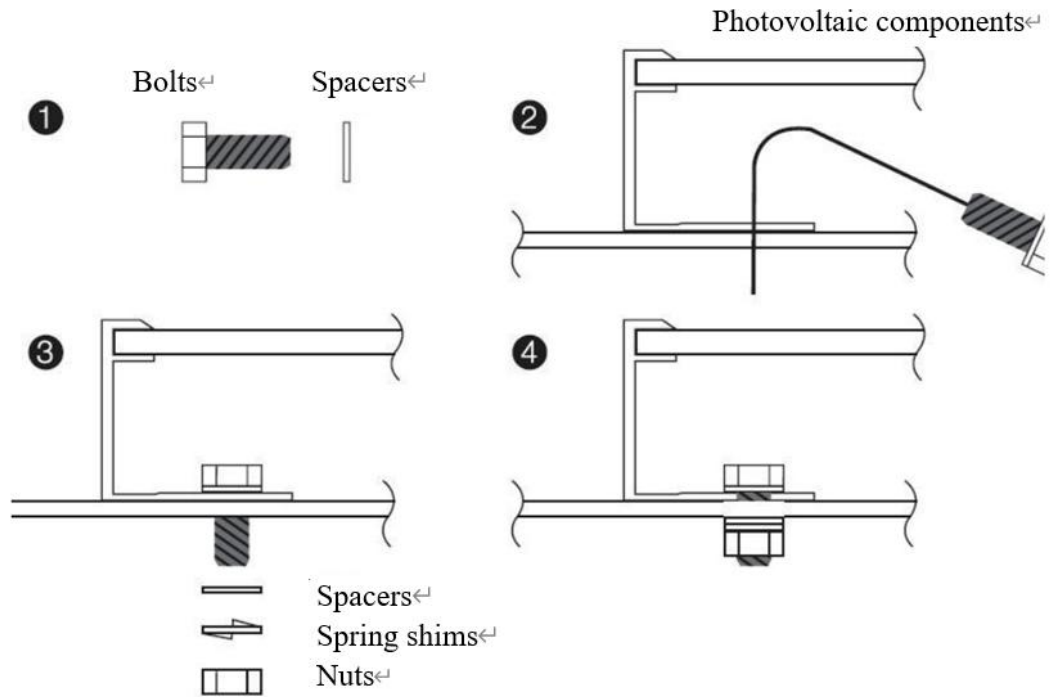

Diagram 2 Installation modes

Name	①Bolt	②Spacers	③Spring shims	④Nuts
Material	stainless	stainless	stainless	stainless
Dimension	M8 *16mm	M8	M8	M8
Remarks	Screw torque size range: 14N.m to 20N.m			
Design value	3600pa			
Safety factor	1.5			

## 2. Modules installed with clamp

Modules should be mounted using specialized clamps as shown in Diagram 3.

A) Modules should be attached on a supporting structure rail by metal clamps. It is recommended to use the clamps under the following condition or approved by system installation:

Width: Clamp A no less than 50mm, Clamp B no less than 38mm;

Thickness: No less than 3mm;

Material: Aluminum Alloy;

Bolt: M8;

B) tighten the screws

C) The Modules clamps must not contact the front glass or deform the frame in any way, the contact area of the clamp with the front of the frame must be smooth,

otherwise may damage the frame or break the modules. Avoid shading effects from the Modules clamps. Drainage holes on the Module frame must not be closed or obscured by the clamps.

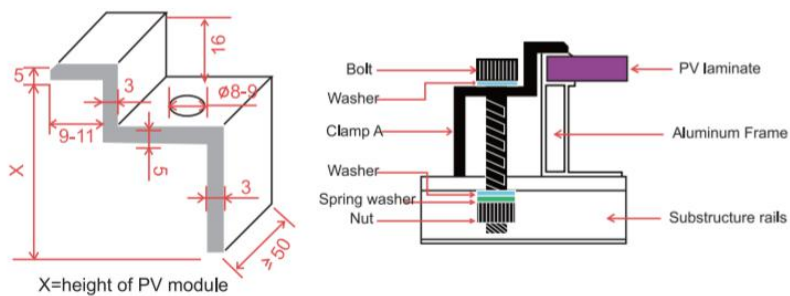
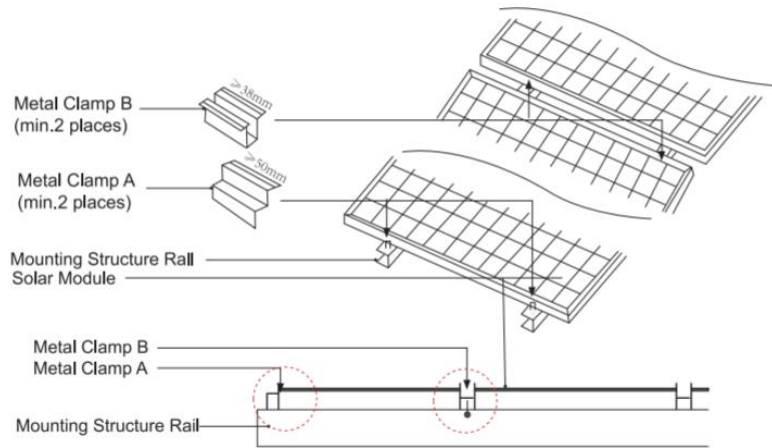

Clamp A

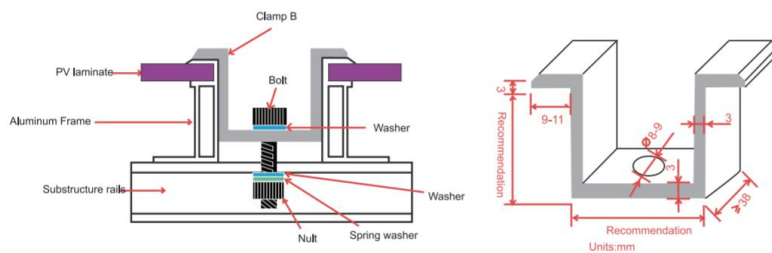

Clamp B

Diagram 3 Clamp Details (Units: mm)

### 3. Installation position and corresponding static loads

The low/normal level of load condition is applicable to the installation in most of environmental conditions: the maximum static load on the back of the modules is 2400 Pa (i.e. wind load), and the maximum static load on the front of modules is 2400 Pa (i.e. wind and snow load).

For the dynamic loads, such as wind, the safety factor needs to be increased by 3 times. It means that the maximum dynamic load is 800 Pa when the wind speed is less

than 130 km/h.

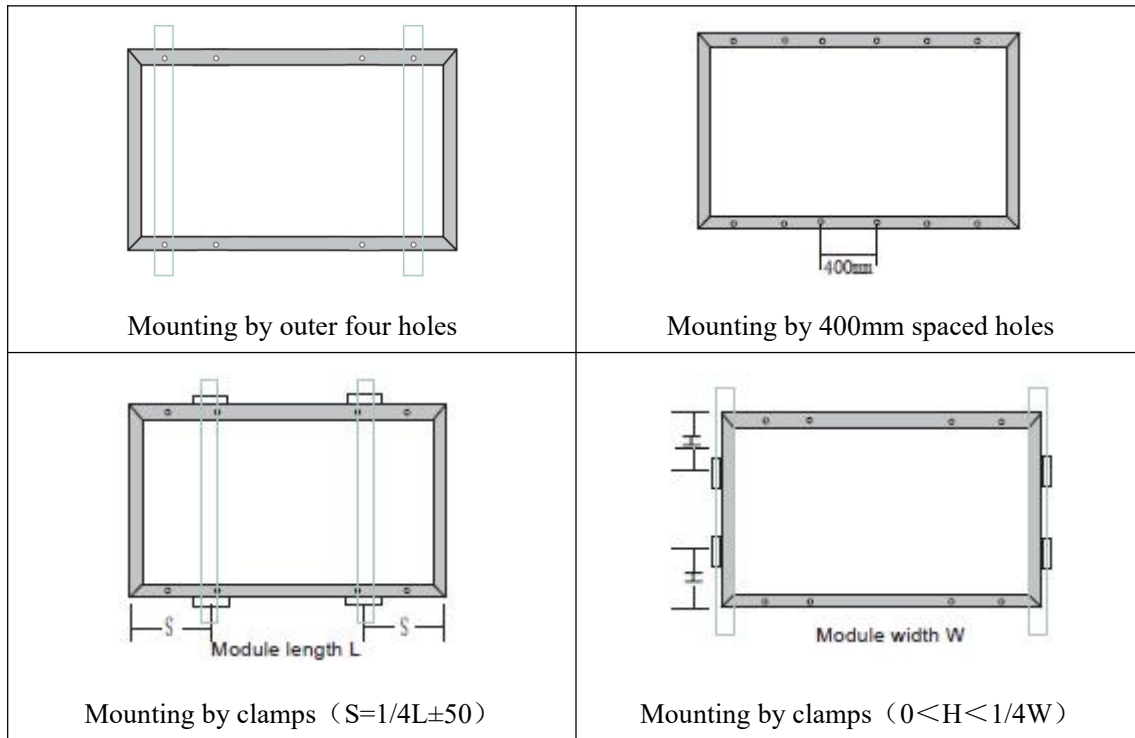

Diagram 4 Installation method

## 7. Electrical installation

### 7.1 Electrical performance

1. Nominal values of the modules electrical performance parameters such as  $I_{sc}$ 、 $V_{oc}$  and  $P_{max}$  have  $\pm 10\%$  deviation range with that under the standard testing conditions. The standard testing conditions for modules are: irradiance  $1000W/m^2$ 、battery temperature  $25^{\circ}C$ 、air mass AM1.5.

2. Under the normal conditions, current and voltage values generated by the modules may slightly greater than the values tested under the standard testing conditions. So when confirming photovoltaic power generation system accessories, such as rated voltage, capacity of conductor, the fuse capacity and the parameters related to the module power output, the corresponding short circuit current and open circuit voltage should be magnified 1.25 times before application.

3. The modules are qualified for application class A: Hazardous voltage (IEC 61730: higher than 50V DC; EN 61730: higher than 120V), hazardous power applications (higher than 240W) where general contact access is anticipated (Modules qualified for



safety through EN IEC 61730-1 and -2 within this application class are considered to meet the requirements for Safety Class II.

4. If modules are connected to a string, the final voltage is the sum of individual modules; if the modules are connected in parallel, the final current is the sum of individual modules, as shown in Diagram 5.

Series connection

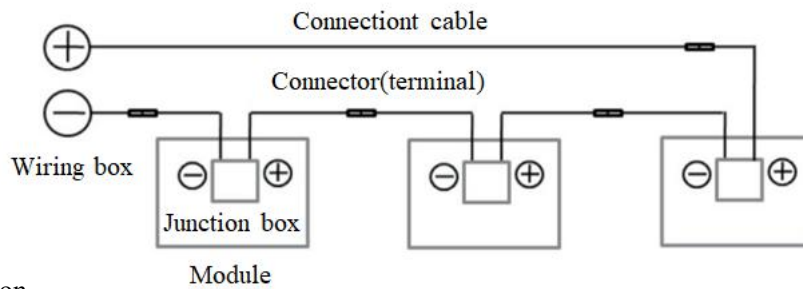

Parallel connection

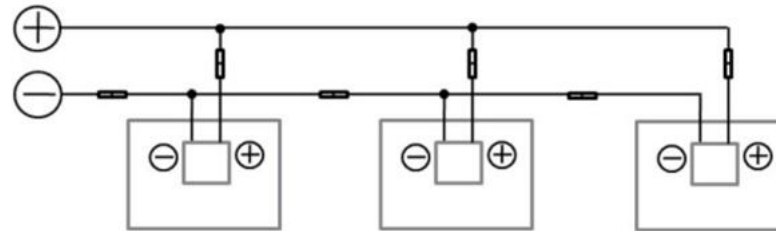

Diagram 5: Electrical diagrams of series and parallel circuits

5. Modules with different models cannot be connected in a string.

6. The maximum number of series connection of each string module must be calculated according to the related rules; the value of its open-circuit voltage under the local anticipated minimum air temperature cannot be greater than the maximum system voltage value stipulated by the modules and the value required by other current electrical parts.

7. Open-circuit voltage correction factor can be calculated according to the following formula:  $C_{Voc} = 1 - \beta V_{oc} \times (25 - T)$ . T is the anticipated minimum environment temperature in the place where system is installed,  $\beta (\% / ^\circ C)$  is the temperature coefficient of  $V_{oc}$  of the selected module (refer to the corresponding module instructions )

8. If reverse current exceeding the maximum current of fuse of a module passes through the module, overcurrent protection equipment with equal specifications must be equipped to protect the module. If the parallel connection number is greater or equal to 2 strings, one overcurrent protection equipment must be equipped on each string module.



9. In the case of parallel installation modules, Used for protection of maximum rated group string protection modules, such as fuse rating shall be greater than 1.5 times that of the short circuit current modules.

## 7.2 Cable and wires

1. In the design of modules, the connection on site uses sealed connecting box whose protection grade reaches IP68, providing wire and its corresponding connection with environmental protection, and providing non-insulation live parts with accessible protection. Connecting box has connected cables and connectors whose protection grade reaches IP68. These designs are convenient for the series connection between the modules. Each module has two wires, an anode, and a cathode, separately connect to the connecting box. Two modules can be connected in series through making a positive pole port of a module wire insert a negative pole port of an adjacent module.

2. Cables on site must be able to meet the maximum short-circuit current of modules. It is suggested that installers only employ sunlight-resistance cables that meet the requirements of photovoltaic current in photovoltaic system, the minimum wire diameter is 4mm<sup>2</sup>.

3. When cables are fixed on the supports, it needs to avoid mechanical damage to cables or modules. Do not overexert to press cables. For fixing cables through appropriate ways, must employ sunlight-resistance bundle and ply-yarn drill with special design to fix cables on supports. Although cables are sunlight-resistance and waterproof, avoiding direct sunlight and cables immersing in water also are needed.

## 7.3 Connectors

1. Please keep connectors dry and clean, ensure nuts of connectors are tightened before connecting, do not connect a connector if the connector is humid, dirty or other conditions. Avoid connectors under direct sunshine and immersing in water. Avoid connectors falling on the ground or rooftops.

2. False connection may generate electric arc and electric shock. Please check all electric connections are right. Make sure all connectors with locks are completely locked.



## 7.4 Bypass diodes

1. Connecting boxes of modules contain bypass diodes, which are connected in parallel on battery string in modules. When part of modules appear in heat spot phenomenon, bypass diodes will let current only pass the battery pieces that never appear in hot spots, thus limit modules fever and performance loss. Pay attention that bypass diode is not overcurrent protection equipment.
2. When know or suspect bypass diodes that have broken down, installers or system maintainer should contact HHDC Solar Power. Please do not try to open the connecting boxes of modules voluntarily.

## 8. Grounding

There is a ground hole with a diameter of 4.3mm in the middle of the border of the module back. The median line and the median line of the ground logo coincide, and the length of the border is consistent. The grounding between modules must be confirmed by qualified electrician, and the grounding device must be made by qualified electrical manufacturers. The recommended torque value is  $2.3\text{N} \cdot \text{m}$ . The ground fixture uses a 12-AWG-size copper core wire. Copper thread cannot be compressed during installation.

The grounding device includes: ground screws, flat pads, star pads and ground cables.



Diagram 6:grounding device includes

We recommend placing the star -shaped pads, flat pads and wires in turn, through screws through the ground holes, and tightening it.

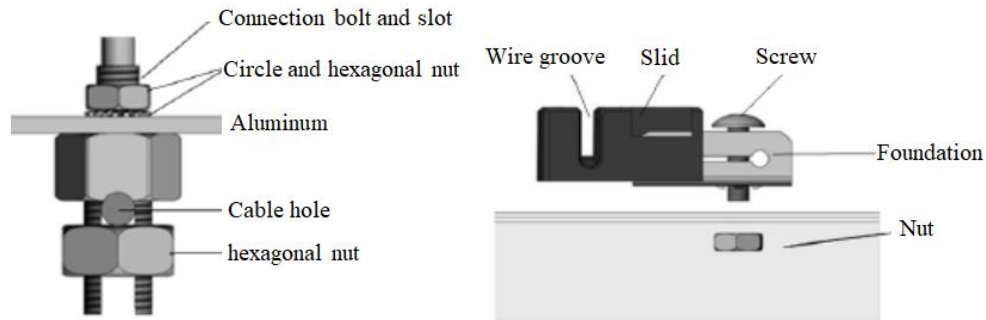

Diagram 7. module ground method

1. Use anodic oxidation and corrosion-resistance aluminum alloy frames as rigid supports in the design of the modules. In order to use safety, avoid modules suffering thunder and lightning and static electricity damage, module frames must be grounded.
2. When grounding, grounding devices must be in contact with the interior of aluminium alloy fully, and penetrates the oxide film on the surface of the frames.
3. Do not drill any additional grounding holes on the frames of the modules.
4. In order to obtain the optimal power output, it is advised that when installing the modules, the DC negative pole of module array is needed to be grounded. In case of failing to operate according to the requirement of this article, the power output of system may be reduced.
5. Module grounding methods cannot lead to electrochemical corrosion occurred between aluminum frames of modules and different kinds of metals.
6. Frames have already been drilled holes and marked with grounding marks in advance. These holes are used only for grounding, and cannot be used to install the modules.

## 9. Operation and Maintenance

Regular inspection and maintenance for modules must be processed, especially within guarantee period, this is the responsibility that users must be undertaken, and users should inform supplier within two weeks upon finding damages of the modules.

### 9.1 Clean

1. Accumulation of dusts on the glass surface of the modules can reduce its power output and may cause the regional hot spots, its influence extent depends on the



transparency of waste, a small amount of dust on the glass will affect the absorbent sunlight strength and evenness; however, it is not dangerous, and power is usually not significantly reduced.

2. When modules are running, environmental impact factors, such as: other modules, module system supports, birds stay, a large amount of dusts, dirt or plants, etc. cannot be existed to cast a shadow on the modules and keep out part or all of the modules, these will result in output power a significantly reduction. It is recommended that modules surfaces cannot be kept out at any time.

3. As for the frequency of cleaning, it depends on the speed of accumulation of dirt. Under normal conditions, the rain will clean the surfaces of the modules, which can reduce the frequency of cleaning. It is recommended to use wet sponge or soft cloth to wipe the glass surfaces. Forbid using detergents containing alkali and acid to clean the modules.

## **9.2 Appearance inspection for modules**

Appearance defects existing in the modules by visual inspection, especially:

1. Whether modules glass has fractured
2. Whether the welding places of battery main girds have rusted
3. Whether the module backboard has a burning trace

## **9.3 Inspection for connectors and cables**

It is recommended that performing once preventive inspection per six months, as follows:

1. Inspect whether the leakproofness of the connectors and cables connections are secure.
2. Inspect whether the sealant in connecting boxes has crazed, whether there is a gap.

# **10. Appendix**

## **10.1 Mono-N-IBC module Electrical Characteristics**



Model 型号	Open Circuit Voltage at STC, STC 状态 (标准 测试状态) 开路 电压 (V dc±3%)	Rated Voltage at STC, STC 状态 额定电压 (V dc)	Maximum System Voltage 最大系统 电压 (V dc)	Rated Current at STC, STC 状态 额定电流 (A dc)	Short Circuit Current at STC, STC 状态短 路电流 (A dc±3%)	Rated Maximum Power at STC, STC 状态额 定最大功率 (Watts±3%)	Maximum Series Fuse, 最大串联 保险丝额 定电流 (A)	NOCT 电池标 称工作 温度 (Deg C.)
SPICN6(LAR)- 60-360/IH	41.3	34.5	1500	10.44	11.17	360	20.0	42±2
SPICN6(LAR)- 60-365/IH	41.4	34.7	1500	10.52	11.28	365	20.0	42±2
SPICN6(LAR)- 60-370/IH	41.5	34.9	1500	10.61	11.39	370	20.0	42±2
SPICN6(LAR)- 60-375/IH	41.6	35.1	1500	10.69	11.50	375	20.0	42±2
SPICN6(LAR)- 60-380/IH	41.7	35.3	1500	10.77	11.61	380	20.0	42±2
SPICN6(LAR)- 60-385/IH	41.8	35.5	1500	10.85	11.72	385	20.0	42±2
SPICN6(LAR)- 60-390/IH	41.9	35.7	1500	10.93	11.83	390	20.0	42±2
SPICN6(LAR)- 66-395/IH	45.4	37.8	1500	10.45	11.16	395	20.0	42±2
SPICN6(LAR)- 66-400/IH	45.5	38.0	1500	10.53	11.26	400	20.0	42±2
SPICN6(LAR)- 66-405/IH	45.6	38.2	1500	10.61	11.36	405	20.0	42±2
SPICN6(LAR)- 66-410/IH	45.7	38.4	1500	10.69	11.46	410	20.0	42±2
SPICN6(LAR)- 66-415/IH	45.8	38.6	1500	10.76	11.56	415	20.0	42±2
SPICN6(LAR)- 66-420/IH	45.9	38.8	1500	10.83	11.66	420	20.0	42±2
SPICN6(LAR)- 66-425/IH	46.0	39.0	1500	10.90	11.76	425	20.0	42±2
SPICN6(LAR)- 66-430/IH	46.1	39.2	1500	10.97	11.86	430	20.0	42±2
SPICN6(LAR)- 72-450/IH	49.9	42.0	1500	10.72	11.66	450	20.0	42±2
SPICN6(LAR)- 72-455/IH	50.0	42.2	1500	10.79	11.72	455	20.0	42±2
SPICN6(LAR)- 72-460/IH	50.1	42.4	1500	10.85	11.78	460	20.0	42±2



SPICN6(LAR)- 72-465/IH	50.2	42.6	1500	10.92	11.84	465	20.0	42±2
SPICN6(LAR)- 40-235/IH	55.6	46.8	1500	5.03	5.37	235	20.0	42±2

The above performance parameters for calibration results on STC, all the parameters deviation range of -3% ~ + 3%.



